

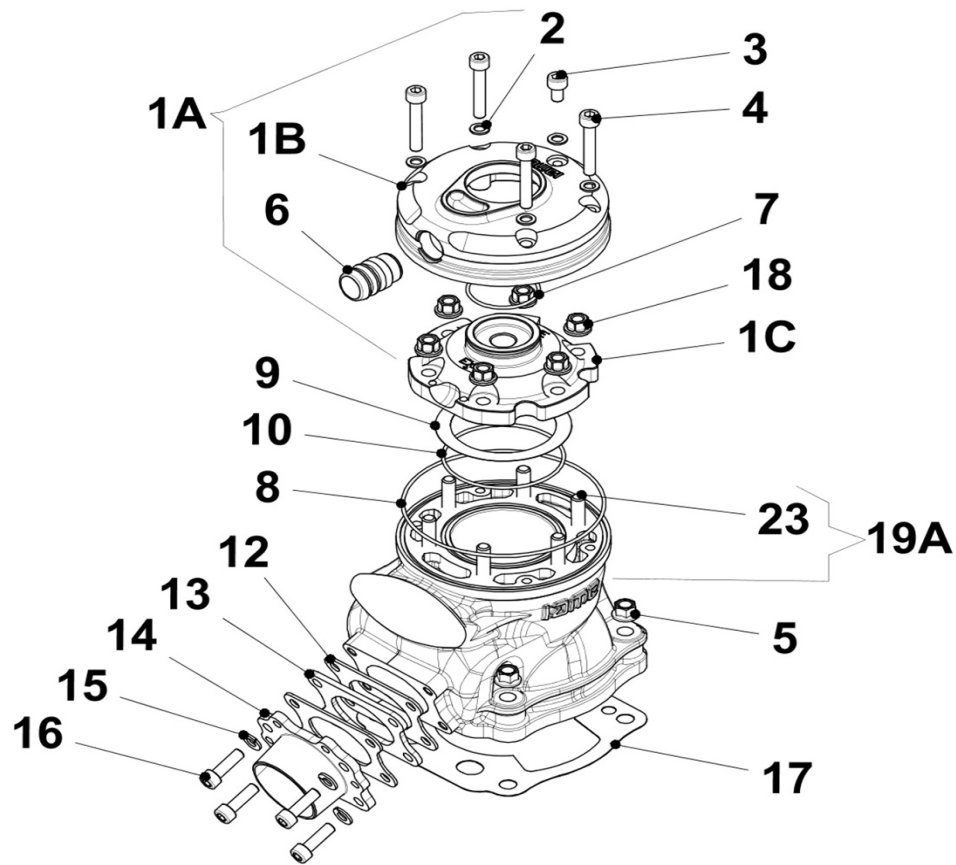

SCREAMER IV - KZ/KZ2 125cc





Z2-901

POS	PART #	DESCRIPTION	USA RETAIL
01B	Z2NA41000	HEAD DOME COVER SCREAMER III	\$ 196.29
01C	Z2NA40101	HEAD DOME SCREAMER III K11	\$ 212.54
02	00345-K	KIT 20 M6 Cu WASHERS	\$ 4.88
03	00069-K	KIT 20 SCREWS TCCE M 6X10 INOX	\$ 8.85
04	00070-K	KIT 20 SCREWS TCCE M 6X35 INOX	\$ 12.38
05	F2NA20300	FLANGED NUT M8	\$ 3.38
06	F2NA40500	WATER PIPE FITTING	\$ 12.04
07	Z1NA42000	OR HEAD DOME SCREAMER '16	\$ 1.80
08	F2NA40300	OR 2400 101.32x1.78 VITON	\$ 4.31
09	IFA-40200-0.05	HEAD GASKET CU 0.05 REED/KZ	\$ 3.68
09	IFA-40200-0.10	HEAD GASKET CU 0.10 REED/KZ	\$ 3.68
09	IFA-40200-0.20	HEAD GASKET CU 0.20 REED/KZ	\$ 4.28
10	IFA-42200	HEAD GASKET INT. OR REEDST/KZ	\$ 10.95
12	Z2NA20500	EXHAUST MANIFOLD GASKET SCREAMER III '19	\$ 9.38
13	Z2NH20500	EXHAUST MANIFOLD SPACER	\$ 35.07
14	Z2NH02001	EXHAUST MANIFOLD SCREAMER III '19	\$ 99.77
15	00331-K	KIT 20 EXHAUST WASHERS M6	\$ 2.51
16	00044-K	KIT 20 ALLEN SCR. CYL. H. 6x20	\$ 3.90
17	Z2NB10400-0.05	CYLINDER BASE GASKET KZ 5/100	\$ 5.63
17	Z2NB10400-0.1	CYLINDER BASE GASKET KZ 1/10	\$ 5.63
17	Z2NB10400-0.2	CYLINDER BASE GASKET KZ 2/10	\$ 5.63
17	Z2NB10400-0.4	CYLINDER BASE GASKET KZ 4/10	\$ 5.63
17	Z2NB10400-0.5	CYLINDER BASE GASKET KZ 5/10	\$ 5.63
18	Z2NA20300	HEAD NUT M7 INOX	\$ 6.19
19A	Z3NA01000-C	CYLINDER SCREAMER IV 2023	\$ 1,129.46
23	Z2NA20400	STUD BOLT INOX M 7 X 39	\$ 6.38

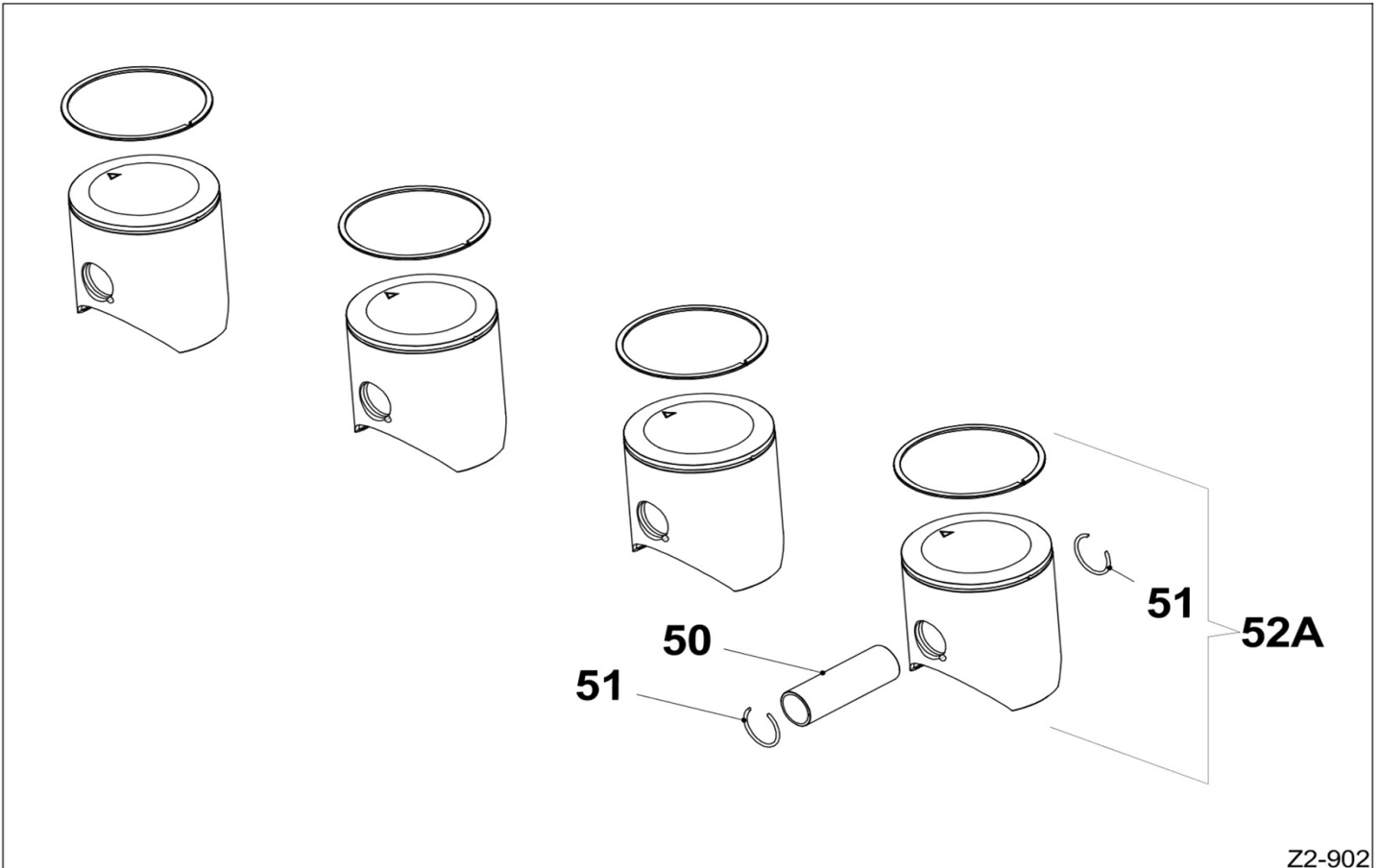

Z2-902

POS	PART #	DESCRIPTION	USA RETAIL
050	IFA-20950	PISTON PIN 15x45	\$ 28.24
051	IFA-21050	CIRCLIP REEDSTER/KZ	\$ 2.51
052A	Z2NA20600-53.93C	PISTON KZ 53.93 COMPL.	\$ 99.64
052A	Z2NA20600-53.94C	PISTON KZ 53.94 COMPL.	\$ 99.64
052A	Z2NA20600-53.95C	PISTON KZ 53.95 COMPL.	\$ 99.64
052A	Z2NA20600-53.96C	PISTON KZ 53.96 COMPL.	\$ 99.64
052A	Z2NA20600-53.97C	PISTON KZ 53.97 COMPL.	\$ 99.64

CRANKCASE & CRANKSHAFT (a)

SCREAMER IV

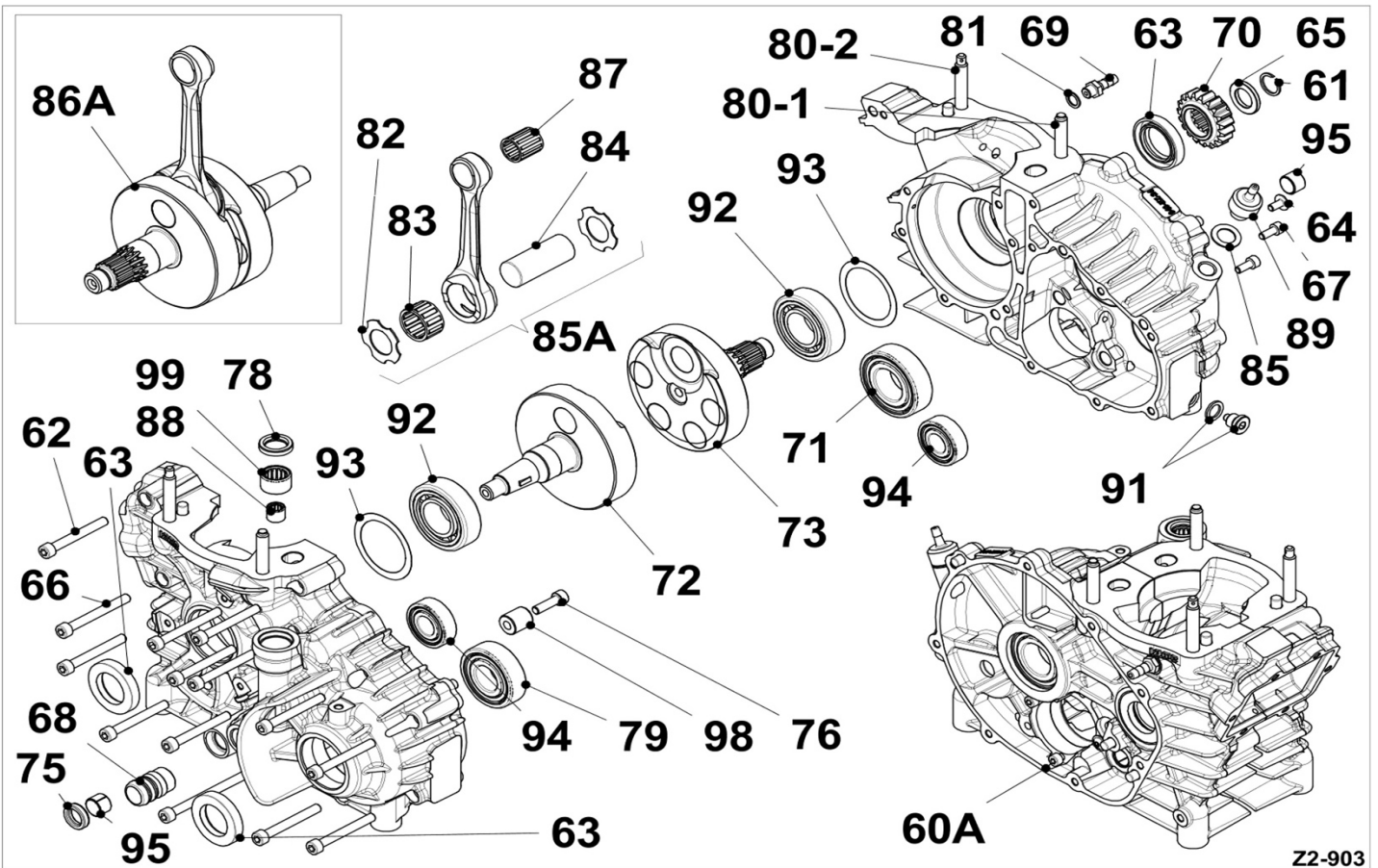

Z2-903

POS	PART #	DESCRIPTION	USA RETAIL
060A	Z3NB01000	CRANKCASE SCREAMER IV 2023	\$ 958.21
61	00389	SEEGER RING SW 15	\$ 0.75
62	00050-K	KIT OF 20 ALLEN SCREWS 6x50	\$ 6.38
63	X30125425A	OIL SEAL MAGN./DRIVE SIDE	\$ 14.67
64	00111-K	20 SCREWS KIT TORX M5x10	\$ 6.04
65	IZC-22500	PRIMARY TRANS. GEAR SPACER	\$ 13.99
66	00051-K	KIT OF 20 ALLEN SCREWS 6x55	\$ 7.99
67	00035-K	KIT 20 ALLEN SCREWS 5x12	\$ 7.69
68	IFA-40500	WATER PIPE FITTING	\$ 8.36
69	D-95800	PRESSURE FITTING	\$ 4.13
70	IZC-22400	PRIMARY TRANSMISS. SPROCKET	\$ 95.42
71	35396-I	BALL BEARING 6205 TN9/C5	\$ 28.24
72	Z2NC30102	HALF CRANCKSHAFT IGN. SIDE SCREAMER III '21	\$ 360.07
73	Z2NC20102	HALF CRANCKSHAFT TR. SIDE SCREAMER III '21	\$ 372.57
75	IZF-90115	OIL SEAL	\$ 6.34
76	00044-K	KIT 20 ALLEN SCR. CYL. H. 6x20	\$ 3.90
78	IZF-90125	OIL SEAL	\$ 6.71
79	10400-D	BALL BEARING 6204 C4	\$ 21.23

CRANKCASE & CRANKSHAFT (b)

SCREAMER IV

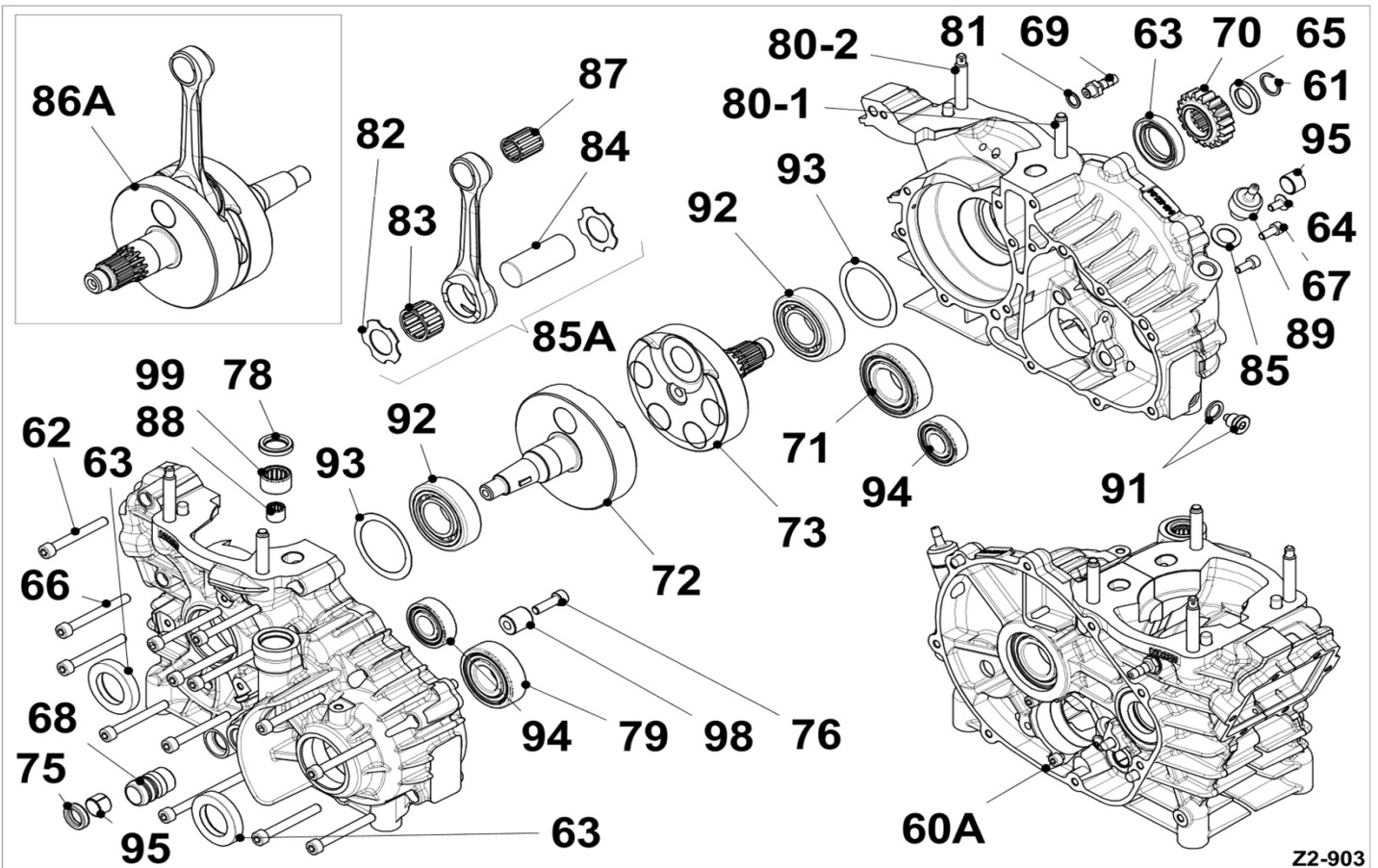

Z2-903

POS	PART #	DESCRIPTION	USA RETAIL
80/1	IFA-20200	STUDBOLT M8x51	\$ 6.26
80/2	IZA-20201	STUDBOLT M8x54 FOR SEALING	\$ 10.65
81	B-71805	PRESSURE Cu FITT. GASKET	\$ 1.46
82	X30125436	SILVER BRONZE WASHER	\$ 8.36
83	X30125431	BIG END CAGE	\$ 56.29
84	S1699/1	CRANK PIN 20x48.8	\$ 34.08
85	IFG-60000	OIL DRAIN FITTING WASHER	\$ 6.49
85A	Z1NC50100-C	CONROD 110mm SCREAMER	\$ 324.81
86A	Z2NC00102	CRANKSHAFT SCREAMER III '21	\$ 1,001.44
87	IFC-50350	SMALL END ROLLER CAGE	\$ 34.09
88	A-60865	ROLLER CAGE TaG	\$ 9.04
89	IFG-50001	OIL DRAIN / REFILL PLUG	\$ 29.78
91	IZF-90505	MAGNETIC PLUG TCEM M10x1	\$ 10.61
92	35398A	ROLLER BEARING 6205 BC1-1442D	\$ 84.39
93	30404	STEEL SHIM 0.15	\$ 2.89
93	30407	STEEL SHIM 0.10	\$ 2.89
94	IZF-90510	BALL BEARING SKF 6202 TN9/C4H	\$ 15.12
95	IZF-90110	BUSH MU TFP 1210	\$ 0.75
98	IZF-22300	SHIFTING DRUM SUPPORT	\$ 20.25
99	IZF-90410A	NEEDLE BEARING HK1412	\$ 20.40

INTAKE

SCREAMER IV

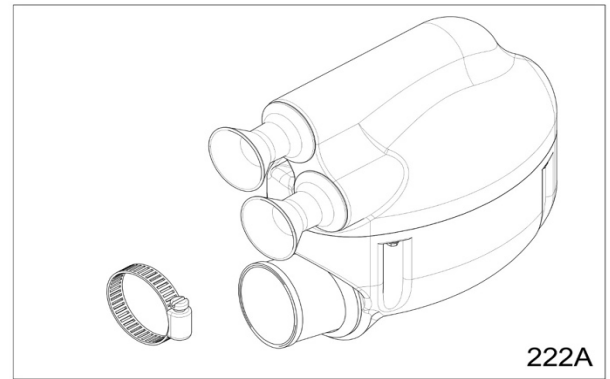
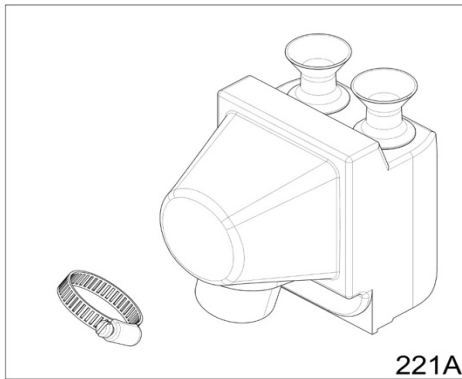
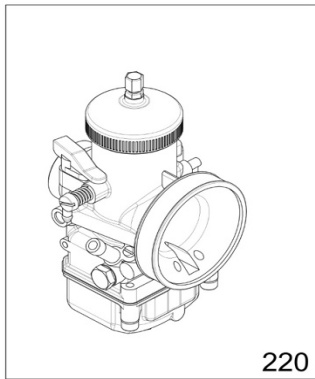
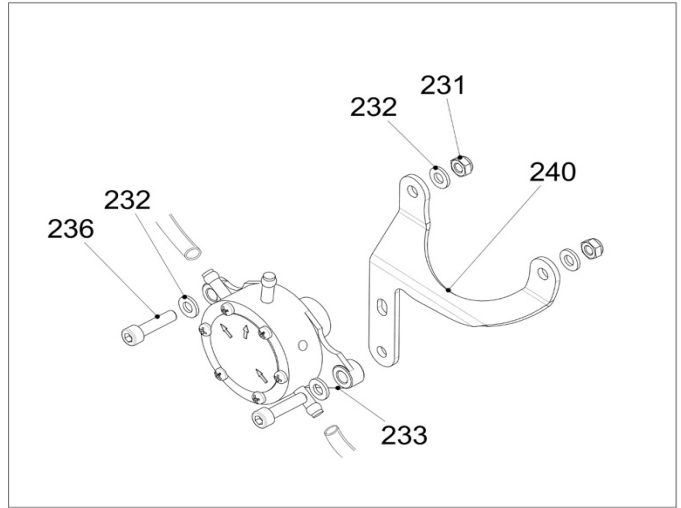
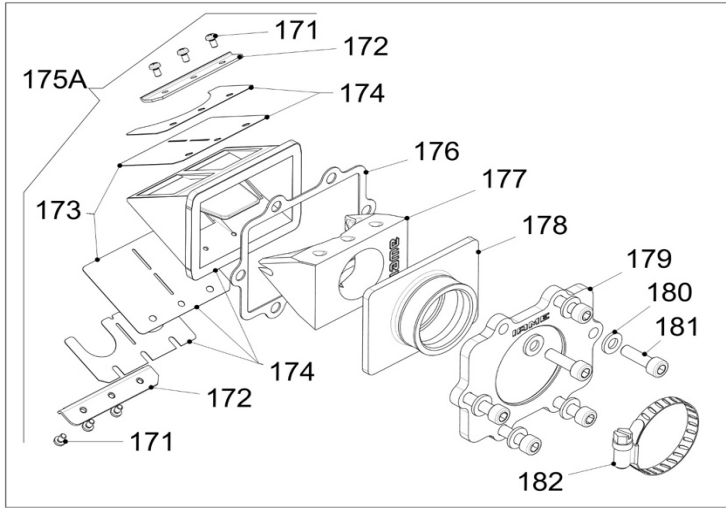

Z2-907

POS	PART #	DESCRIPTION	USA RETAIL
171	10380	REEDS SCREW	\$ 1.46
172	IZG-20200	REED PETALS LOCKING PLATE	\$ 4.88
173	IZG-20300-C1	KIT CARB.REED PET.0.30/0.33 KZ	\$ 73.76
174	IZG-20300-C	KIT CARB.REED PET.0.30/0.33 KZ	\$ 104.04
175	IZG-02000	REED VALVE ASSEMBLY KZ	\$ 279.58
176	IZB-41150	CARBURETTOR MANIFOLD GASKET	\$ 6.15
177	Z2NB41000	CONVEYOR PYRAMID SCREAMER III '19	\$ 69.14
178	IZB-41551	CARBURETTOR RUBBER MANIFOLD	\$ 37.71
179	IZB-41350N	CARBUR. MANIFOLD FLANGE BL	\$ 51.43
180	00321-K	20 ONDULATING WASHERS KIT	\$ 2.48
181	00043-K	KIT OF 20 SCREWS TCCE 6x18	\$ 3.90
182	IZG-31100	SCREW CLAMP	\$ 14.59
220	IFG-00100KZ20E	CARBURAT. DELL'ORTO VSH 30CS reg. 2020 Set "E"	\$ 500.94
231	00378-K	20 SELF LOCKING NUTS KIT M6	\$ 4.13
232	00302-K	KIT 20 WASHERS M6	\$ 1.46
233	IZG-90001	FUEL PUMP	\$ 106.82
234	B-35810	COIL DAMPENER	\$ 9.24
236	00045-K	KIT 20 SOCKET H. SCREWS M6X25	\$ 3.90
240	Z2NG40800	FUEL PUMP SUPPORT BRACKET	\$ 18.38

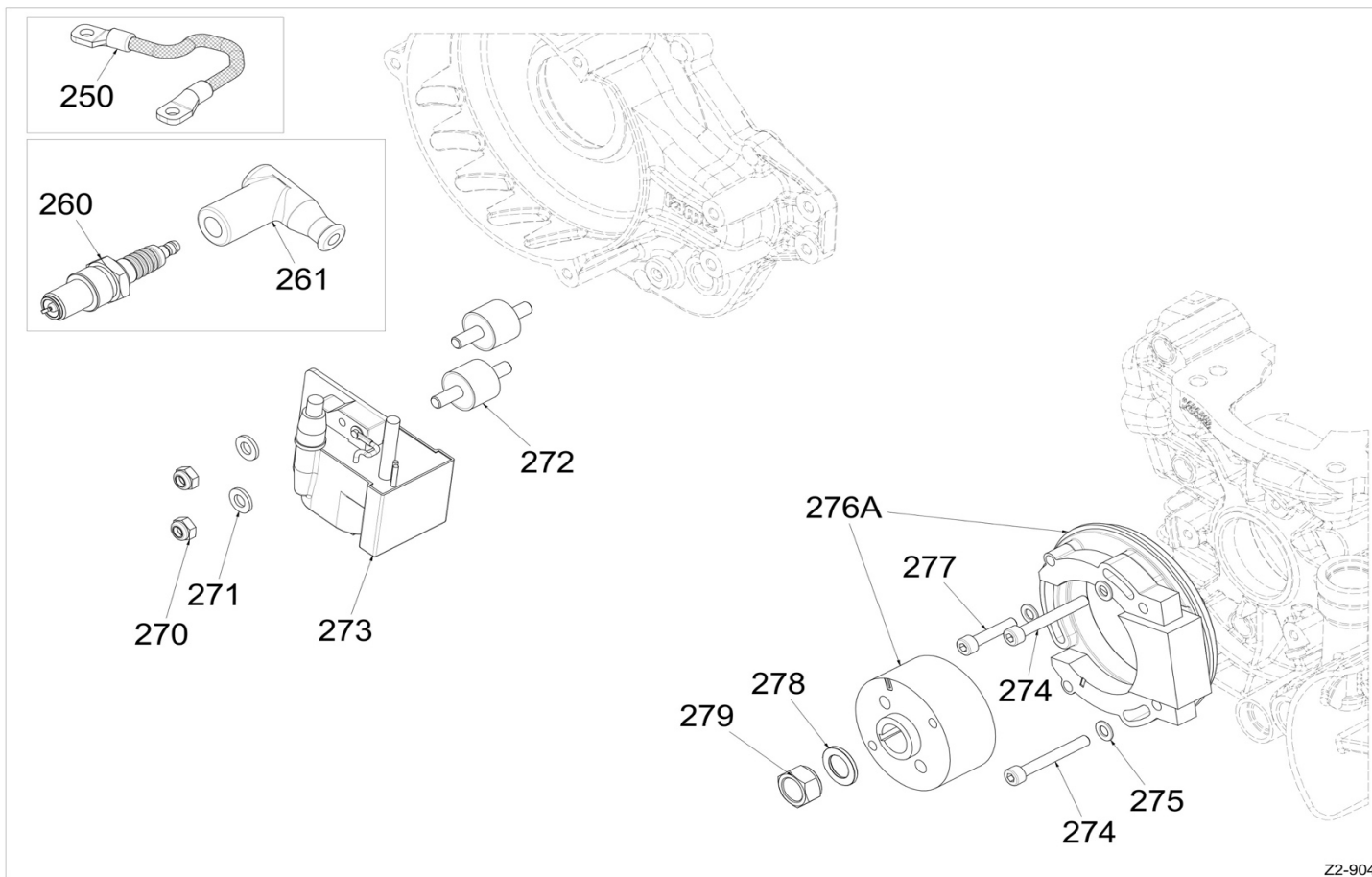

Z2-904

POS	PART #	DESCRIPTION	USA RETAIL
250	B-35805-A	COIL GROUND CABLE	\$ 6.71
260	10561-A	SPARK PLUG NGK BR10EG	\$ 29.44
261	10544	PVL SPARK PLUG CAP BLACK	\$ 23.10
270	00378-K	20 SELF LOCKING NUTS KIT M6	\$ 4.13
271	00302-K	KIT 20 WASHERS M6	\$ 1.46
272	B-35810	COIL DAMPENER	\$ 9.04
273	10026	PVL COIL	\$ 99.94
273	10026S	ANALOGIC COIL SLT A18N88 034-IG-14	\$ 165.69
274	00039-K	KIT OF 20 ALLEN SCREWS 5x40	\$ 8.48
275	00301-K	KIT 20 WASHERS M5	\$ 1.46
276A	10016-A	PVL-SUPER IGNITION	\$ 206.54
276A	10016S	ANALOGIC IGNITION SLT A18N88 034-IG-14	\$ 222.96
277	00036-K	KIT OF 20 ALLEN SCREWS 5x30	\$ 3.75
278	D-75565	THRUST INT.WASHER H=1,8mm	\$ 4.13
279	10535	SPROCKET AND MAGNETO NUT	\$ 4.13

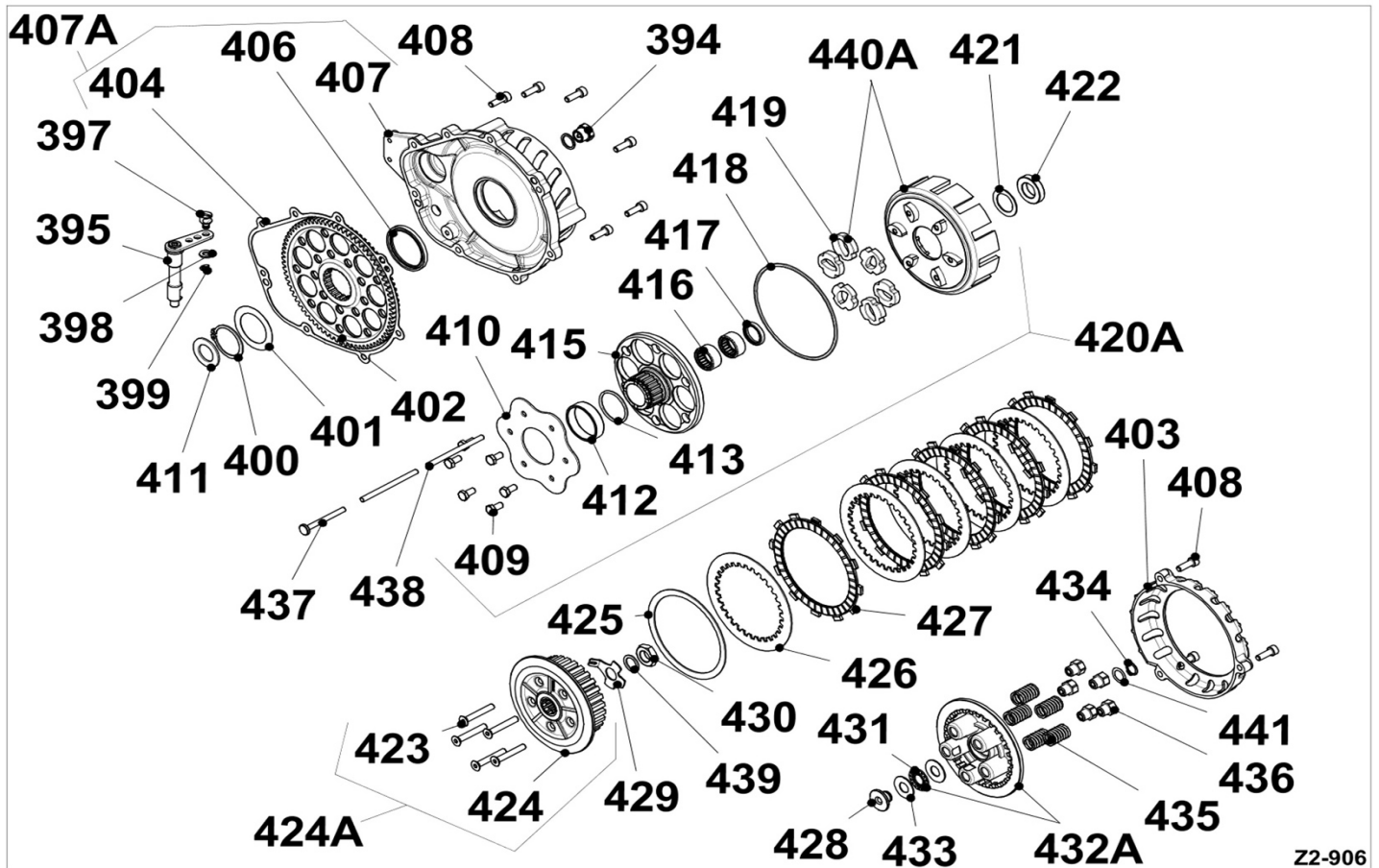

Z2-906

POS	PART #	DESCRIPTION	USA RETAIL
394	IZB-90000	OIL LEVEL GAUGE	\$ 10.13
395	Z2NF01800	CLUTCH LEVER	\$ 44.76
396	Z2NF90065	SEEGER UNI 7434 - 5 5 mm	\$ 3.38
397	Z2NF02600	CLUTCH CABLE SEAT PIN	\$ 31.88
398	00302-K	KIT 20 WASHERS M6	\$ 1.46
400	IZF-90070	SEEGER RING A35 DIN471	\$ 0.98
401	IZF-90060	SAFETY CONE SPRING	\$ 3.75
402	IZF-02402	PRIMARY DRIVEN GEAR	\$ 212.54
403	Z2NB40700	CLUTCH COVER SCREAMER III	\$ 112.27
404	Z2NB40300	GASKET PRIMARY TRANSM. COVER	\$ 5.96
406	Z2NF90000	OIL SEAL G42x52x4	\$ 12.19
407	Z2NB40200	PRIMARY TRANSMISSION COVER SCREAMER III '19	\$ 205.04
408	00043-K	KIT OF 20 SCREWS TCCE 6x18	\$ 3.90
409	00161-K	KIT OF 20 HEX. SCREWS 6x12	\$ 4.03
410	IZF-00900	SHOCK ABSORBER PLATE	\$ 14.29
411	IZF-02500	SHIM PRIMARY DRIVEN GEAR	\$ 9.79
412	Z2NF01100	OIL SEAL BUSH	\$ 23.63
413	IZF-90030	O'RING 3131 FPM 75	\$ 2.18
415	IZF-01000	SHOCK ABSORBER HUB	\$ 187.54
416	IZF-90000	NEEDLE BEARING	\$ 13.62
417	IZF-90015	OIL SEAL G20x26x4B	\$ 12.68
418	IZF-90035	OIL SEAL	\$ 1.39
419	IZF-00800	DAMPER SHOCK ABSORBER	\$ 2.25

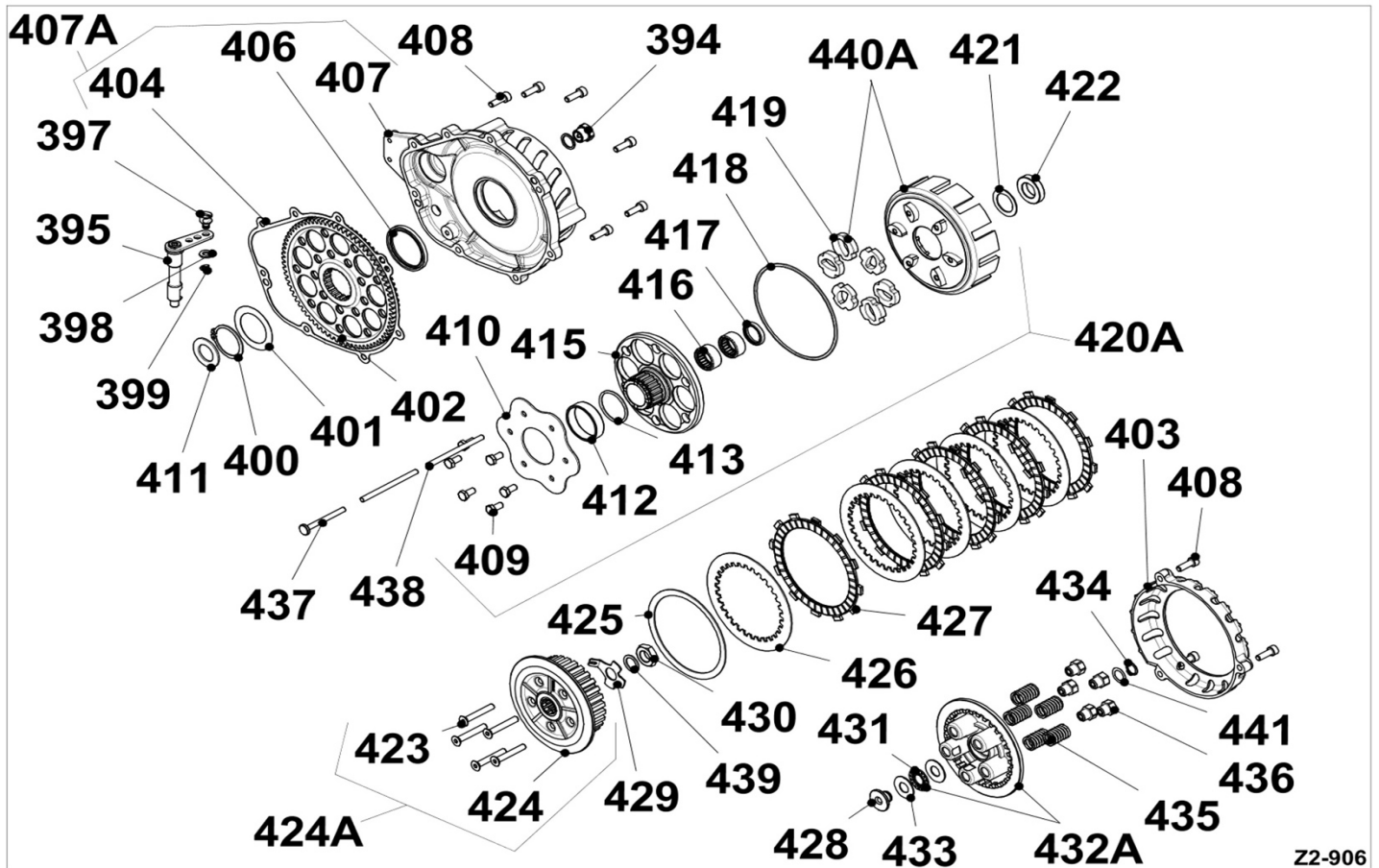

Z2-906

POS	PART #	DESCRIPTION	USA RETAIL
420A	Z2NF00201	SHOCK ABSORBER ASSEMBLY	\$ 357.57
421	IZF-90080	SPACER RING PS 22x32x1	\$ 1.99
422	IZF-02200	CLUTCH DRUM SPACER	\$ 15.19
423	00130-K	KIT 20 SCREWS TSEI M6x40	\$ 8.89
424	Z2NF00500	CLUTCH DRUM	\$ 99.02
425	IZF-02100	SAFETY CONE SPRING	\$ 9.60
425	IZF-02100	SAFETY CONE SPRING	\$ 9.60
426	IZF-00700	BARE CLUTCH DISC	\$ 7.88
426	IZF-00701	BARE CLUTCH DISC ERGAL R.T.	\$ 33.06
427	IZF-00600	PADDED CLUTCH DISC	\$ 26.20
427	IZF-00600A	PADDED CLUTCH DISC R.T.	\$ 36.61
428	Z2NF01400	THRUST BEARING PLATE	\$ 18.75
429	IZF-01700	CLUTCH NUT WASHER	\$ 8.66
430	00364	NUT M14x1	\$ 19.13
431	Z2NF90460	AXIAL ROLLER BEARING	\$ 12.56
432A	Z2NF04000	PRESS. PLATE COMPLETE	\$ 77.26
433	Z2NF90461	AXIAL BEARING BUSH	\$ 3.19
434	G-100571	SEEGER RING 12x1	\$ 1.84
435	Z2NF01200	THRUST PLATE SPRINGS	\$ 3.38
436	Z2NF01300	CLUTCH SPRING RETAINER	\$ 12.38
437	IZF-01600	CLUTCH PUSH PLATE	\$ 16.32
438	IZF-01500	PUSH ROD CLUTCH	\$ 4.35
439	IZF-02300	CLUTCH NUT WASHER	\$ 8.33
440A	Z2NF00300	CLUTCH DRUM	\$ 92.02
441	Z2NF90090	SPACER RING	\$ 1.31

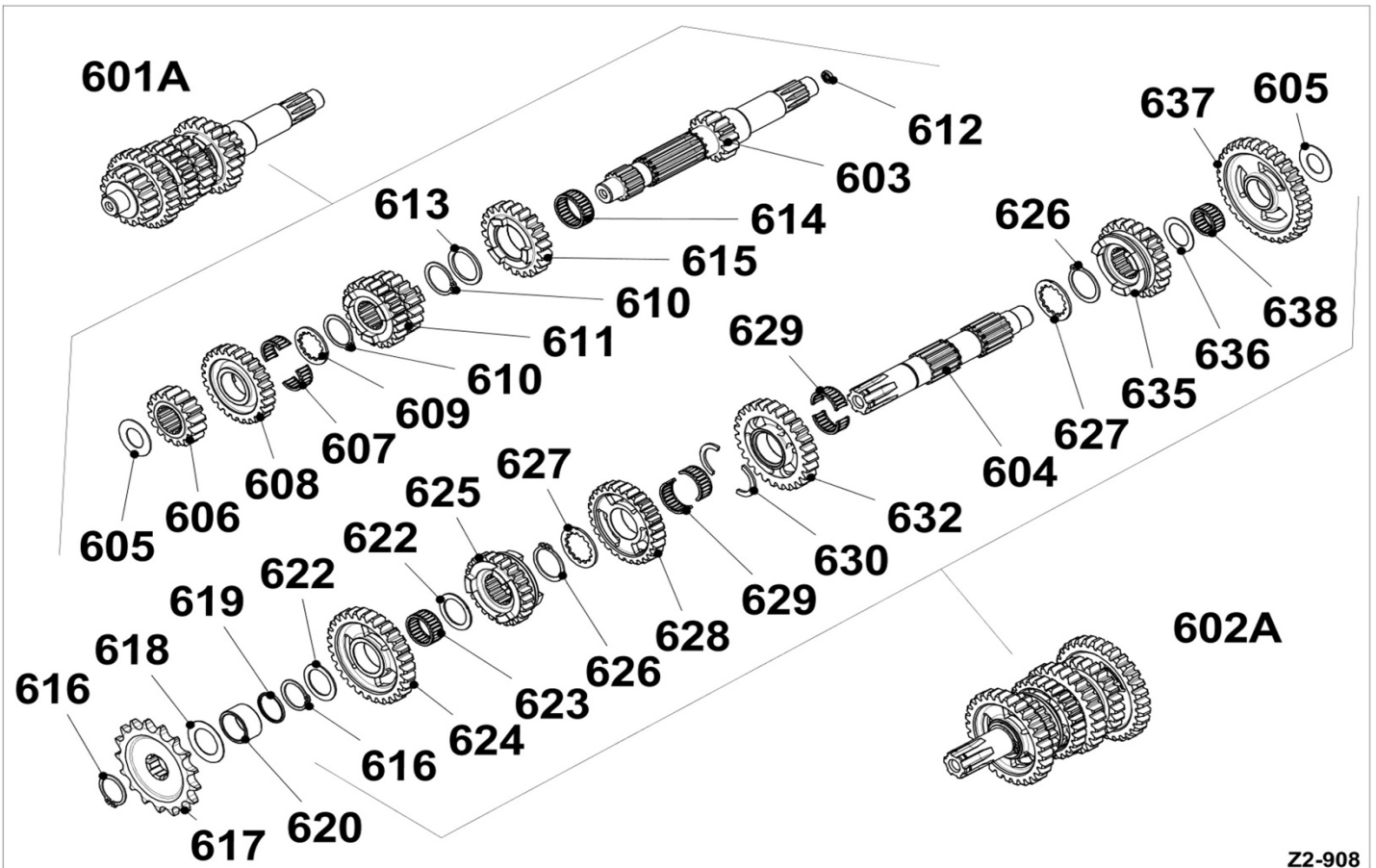

Z2-908

POS	PART #	DESCRIPTION	USA RETAIL
601A	IZF-30001	COMPL. PRIMARY SHAFT SCREAMER	\$ 881.52
602A	IZF-31001	COMPL. SECONDARY SHAFT SCREAMER	\$ 841.76
603	IZF-20100	PRIMARY SHAFT	\$ 218.79
604	IZF-20200	SECONDARY SHAFT	\$ 206.29
605	IZF-21900	SHIM PRIMARY/SECONDARY SHAFT	\$ 2.74
606	IZF-20300	2nd G. DRIVE GEAR	\$ 75.59
607	IZF-20450	SPLITTED ROLLER CAGE K18x22x10	\$ 33.03
608	IZF-20650	6th G. DRIVE GEAR	\$ 107.07
609	IZF-21400	SPLINED SHIM 6th SPEED	\$ 10.09
610	IZF-90045	SEEGER RING A22 DIN471	\$ 0.53
611	IZF-20400	3rd/4th G. DRIVE GEAR	\$ 137.10
612	IZF-90020	OIL SEAL GR5x9x2	\$ 11.14
613	IZF-21300	5th GEAR SHIM	\$ 4.91
614	IZF-20452	ROLLER CAGE	\$ 11.89
615	IZF-20500	5th G. DRIVE GEAR	\$ 88.77
616	IZF-90055	SEEGER RING A20 DIN471	\$ 0.49
617	IZF-25800	SPROCKET Z15	\$ 38.86
617	IZF-25900	SPROCKET Z16	\$ 38.86
617	IZF-26000	SPROCKET Z17	\$ 38.86
617	IZF-26100	SPROCKET Z18	\$ 38.86
617	IZF-26200	SPROCKET Z19	\$ 38.86
617	IZF-26300	SPROCKET Z20	\$ 38.86
618	IZF-90120	SAFETY CONE SPRING "AL"	\$ 1.46
619	IZF-90025	O'RING 2075 NBR 70	\$ 0.30

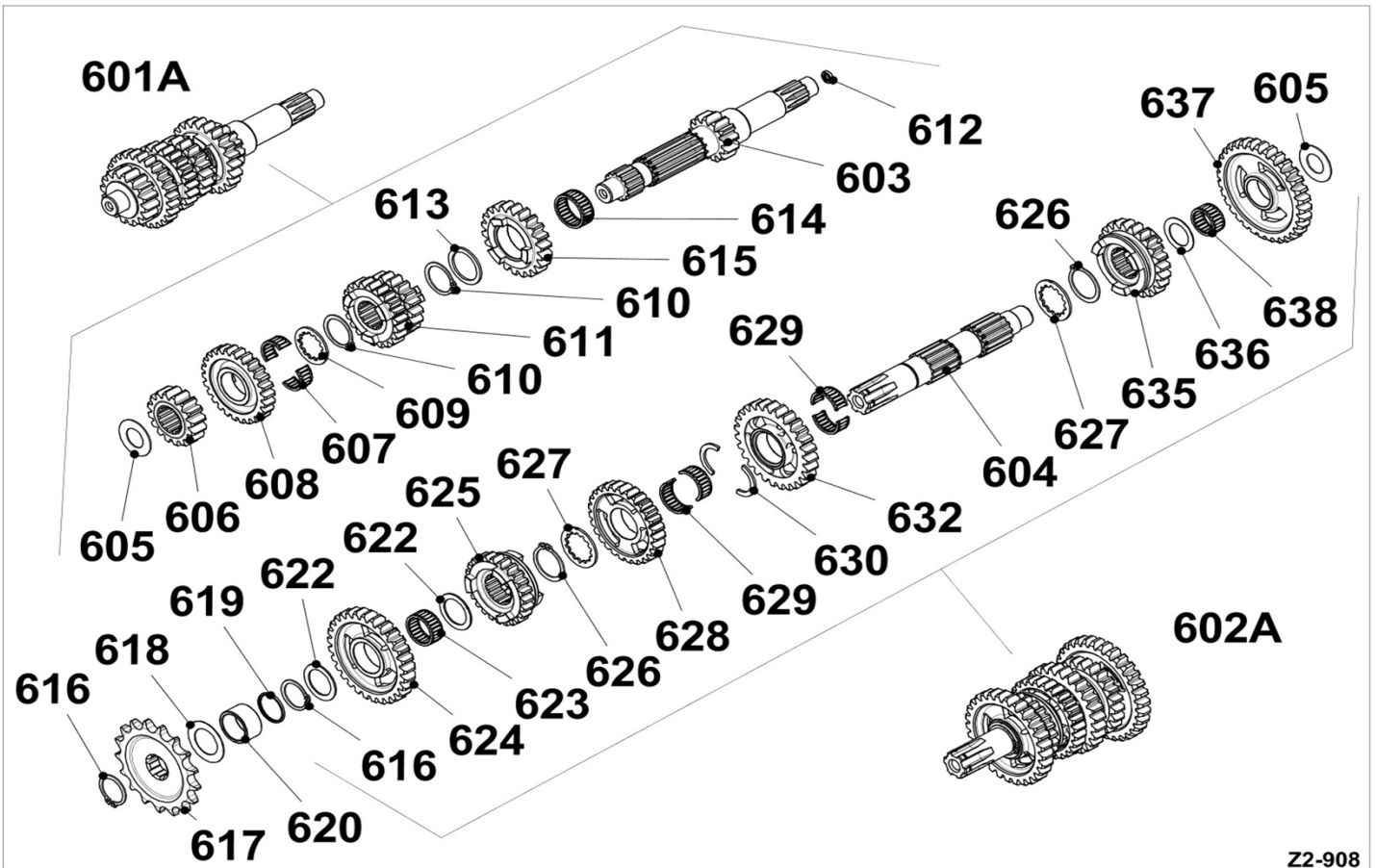

Z2-908

POS	PART #	DESCRIPTION	USA RETAIL
620	IZF-25300	CHAIN SPROCKET SPACER	\$ 30.87
622	IZF-90075	SPACER RING	\$ 2.18
623	IZF-90400	ROLLER CAGE K20	\$ 13.69
624	IZF-20800	2nd G. DRIVEN GEAR	\$ 126.52
625	IZF-21250	6th G. DRIVEN GEAR	\$ 126.47
626	IZF-90050	SEEGER RING A24 DIN471	\$ 0.71
627	IZF-21700	SPLINED SHIM 21x32x0.8	\$ 8.36
628	IZF-21000	4th G. DRIVEN GEAR	\$ 116.55
629	IZF-20451A	SPLIT. ROLLER CAGE K20x24x10	\$ 33.03
630	IZF-21800	HALF SHIM 3rd / 4th SPEED	\$ 4.24
632	IZF-20900	3rd G. DRIVEN GEAR	\$ 156.53
635	IZF-21100	5th G. DRIVEN GEAR	\$ 113.27
636	IZF-21500	SHIM 1st SPEED	\$ 4.58
637	IZF-20750	1st G. DRIVEN GEAR	\$ 142.60
638	IZF-90405	ROLLER CAGE K17	\$ 16.88

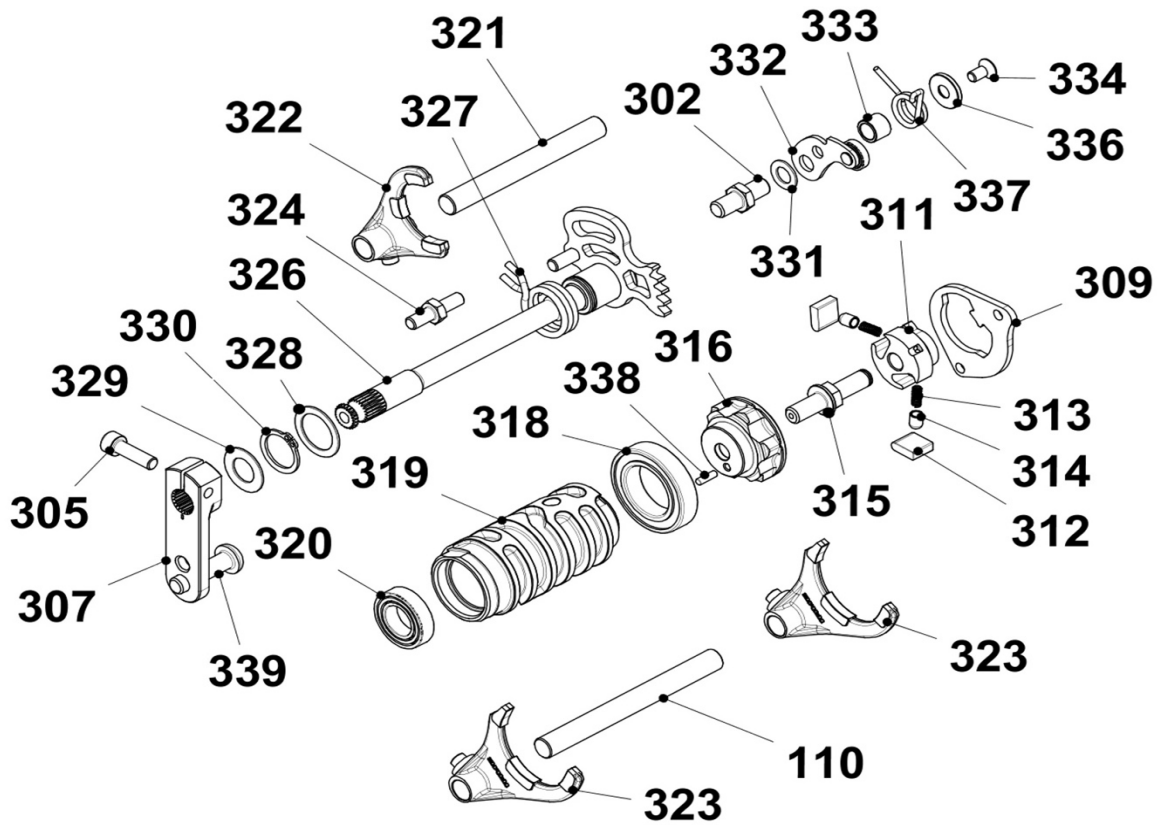

Z2-905

POS	PART #	DESCRIPTION	USA RETAIL
110	IZF-22800	FORKS GUIDE SHAFT	\$ 18.23
302	Z2NF24100	GEAR POSITION LEVER PIN	\$ 9.38
305	00044-K	KIT 20 ALLEN SCR. CYL. H. 6x20	\$ 3.90
307	Z2NF24900	SHIFT LEVER	\$ 39.96
309	Z2NF23800	RATCHET PLATE	\$ 16.88
311	Z2NF03000	RATCHET SUPPORT COMPLETE	\$ 81.27
312	IZF-23400	SHIFTING RATCHET	\$ 18.38
313	IZF-23601	RATCHET PUSH PAD	\$ 1.80
314	IZF-23500	PUSH ROD RATCHET	\$ 8.06
315	Z2NF22900	SHIFTER PIN	\$ 28.13
316	IZF-22000	PRESELECTOR CAM	\$ 103.32
318	IZF-90450	BALL BEARING 6905 T1xC3	\$ 45.83
319	Z2NF22200	SHIFT CAM	\$ 118.77
320	IZF-90455	BALL-BEARING 61902 T9C4	\$ 28.31
321	Z2NF22800	FORKS DRIVE SHAFT PRIMARY	\$ 67.51
322	Z2NF22400	SHIFTING PRIMARY FORK	\$ 149.78
323	IZF-22600CR	SHIFTER SECONDARY FORK	\$ 125.02
324	Z2NF24800	SELECTOR SPRING COUNTER PIN	\$ 14.07
326	Z2NF23100	SELECTOR SHAFT	\$ 113.77
327	Z2NF24000	PRESELECTOR SHAFT SPRING	\$ 7.50
328	Z2NF25700	STEEL SHIM SELECTOR	\$ 6.75
329	Z2NF90076	SELECTOR SHAFT BUSH	\$ 5.63
330	Z2NF90070	SEEGER / SHAFT 18 mm	\$ 1.13
331	Z2NF90075	STEEL SHIM GEAR POSITION LEVER	\$ 3.38
332	Z2NF24600	GEAR POSITION LEVER	\$ 35.63
333	Z2NF24500	BUSHING GEAR POSITION SPRING	\$ 13.13
334	00111-K	20 SCREWS KIT TORX M5x10	\$ 6.04
336	Z2NF24200	SPRING WASHER	\$ 14.07
337	Z2NF24700	GEAR POSITIONING LEVER SPRING	\$ 9.38
338	IZF-90085	NEEDLE N3x9.8 AB2	\$ 20.44

EXHAUST GROUP & GASKETS

SCREAMER IV

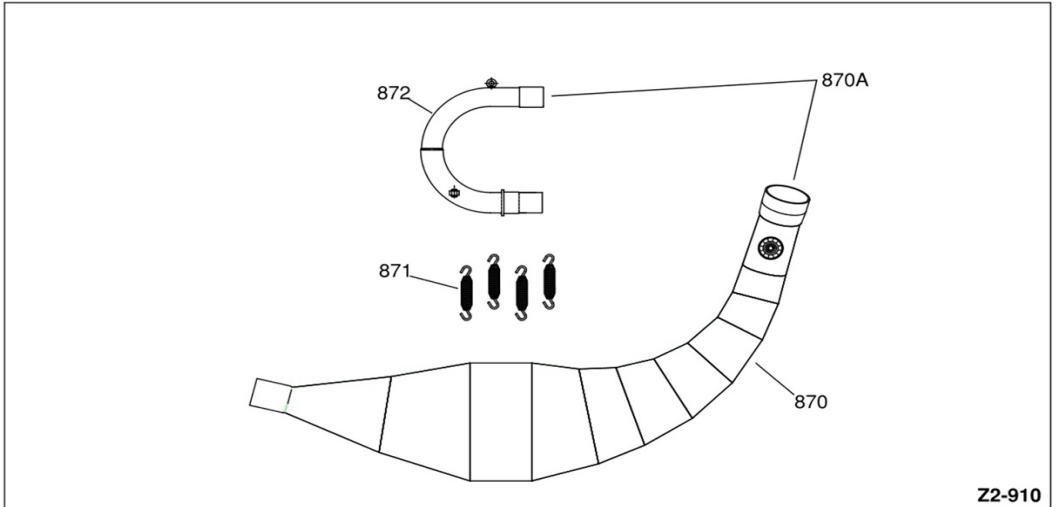
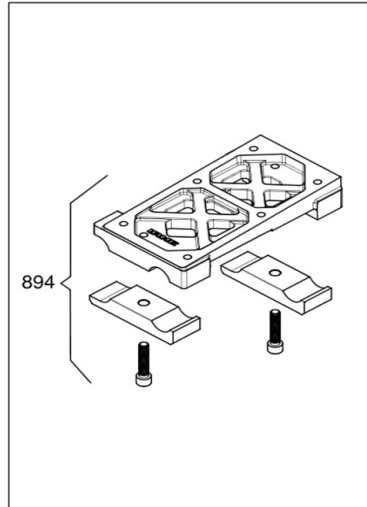
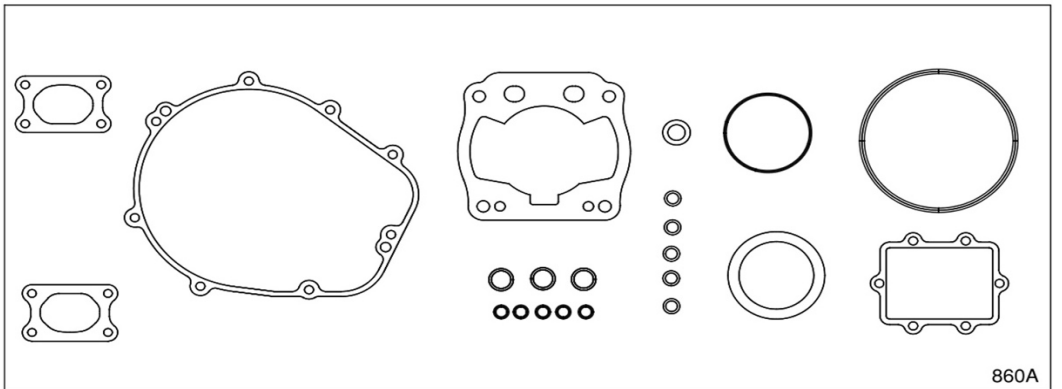
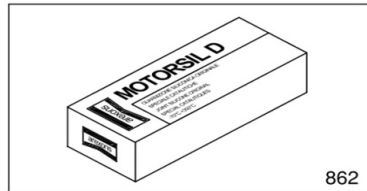

POS	PART #	DESCRIPTION	JSA RETAIL
860A	Z2NZ00001	GASKET SET SCREAMER III	\$ 30.38
861	00600	PIPE FITTING SEAL	\$ 25.15
862	00602	GASKET AREXON	\$ 43.59
870A	Z3NH04000-C	EXHAUST MUFFLER SCREAMER IV W. TAIL PIPE - ST23	\$ 450.08
870A	Z3NH04000EV122-C	EV122 SPECIAL EXHAUST PIPE KZ SCREAMER 4 W. TAIL PIPE	\$ 450.08
870A	Z3NH04000EV125-C	EV125 SPECIAL EXHAUST PIPE KZ SCREAMER 4 W. TAIL PIPE	\$ 450.08
871	Z3NH55100	EXHAUST SPRING	\$ 10.04
872	IZH-06101	TAIL PIPE KZ 26/28mm	\$ 60.96
894	Z3NB50000-C	COMPLETE ENGINE MOUNT	\$ 246.30

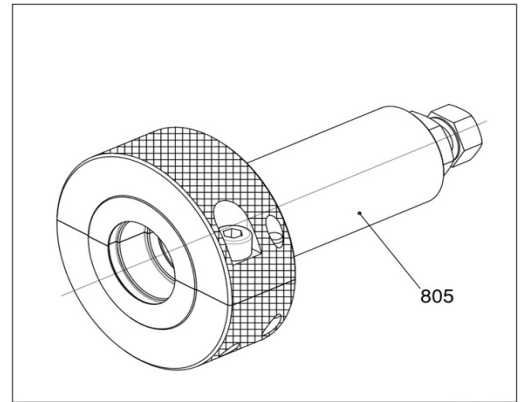
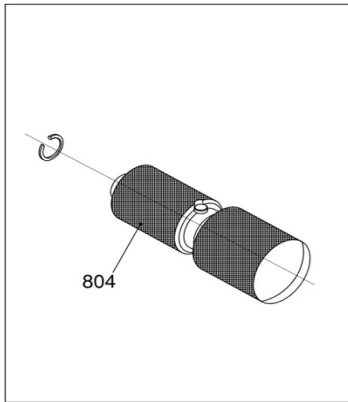
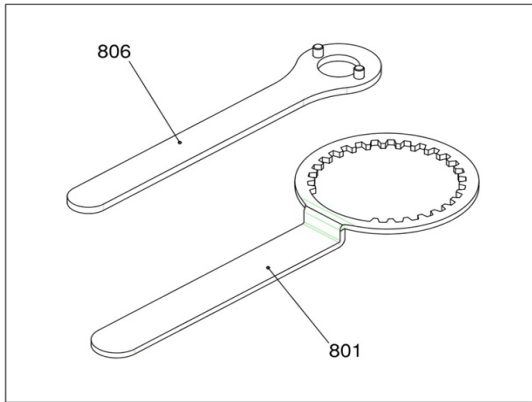
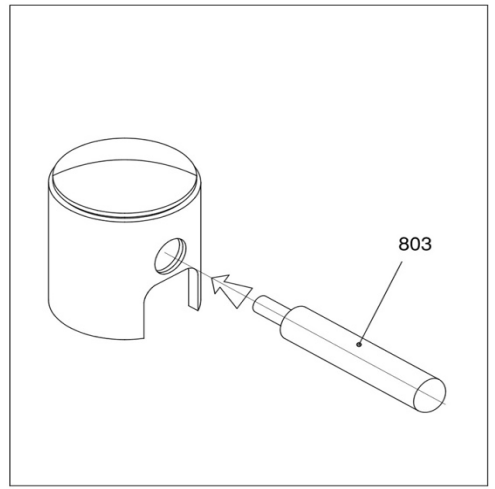
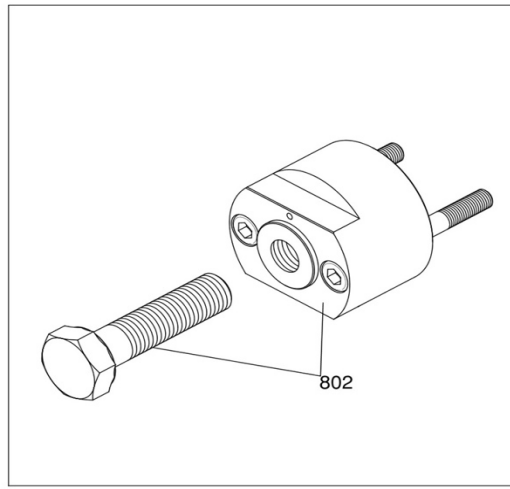
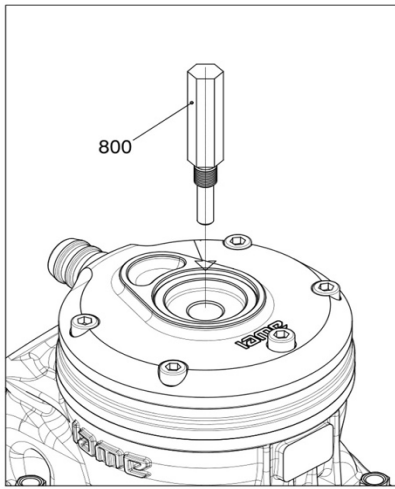

Z2-912

POS	PART #	DESCRIPTION	USA RETAIL
800	10271	PISTON STROKE LOCKER	\$ 29.78
801	ATT-031/2	CLUTCH DRUM LOCKING TOOL	\$ 31.88
802	10826-C	ROTOR PULLER PVL/SELETTRA	\$ 28.18
803	ATT-017	PISTON PIN PUNCH d.15mm	\$ 21.30
804	ATT-006	CIRCLIP 15mm ASSEM.TOOL	\$ 135.88
805	ATT-048	BEARING RING PULLER	\$ 312.21
806	10137	ROTOR WRENCH PVL/SELETTRA	\$ 35.16

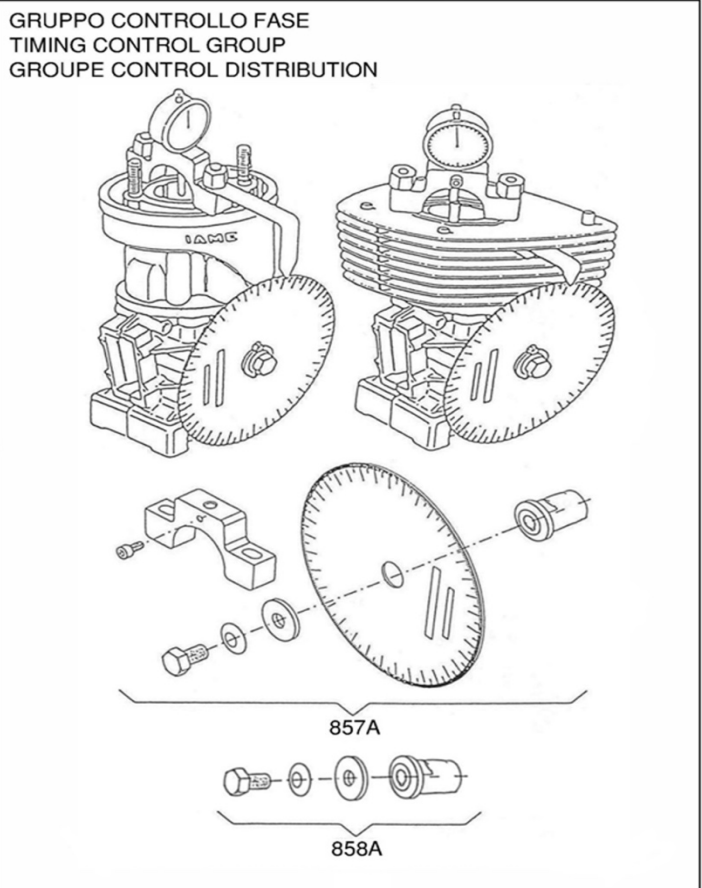
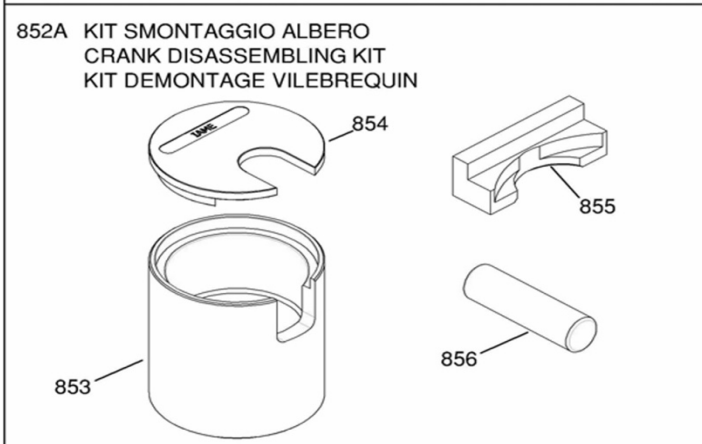
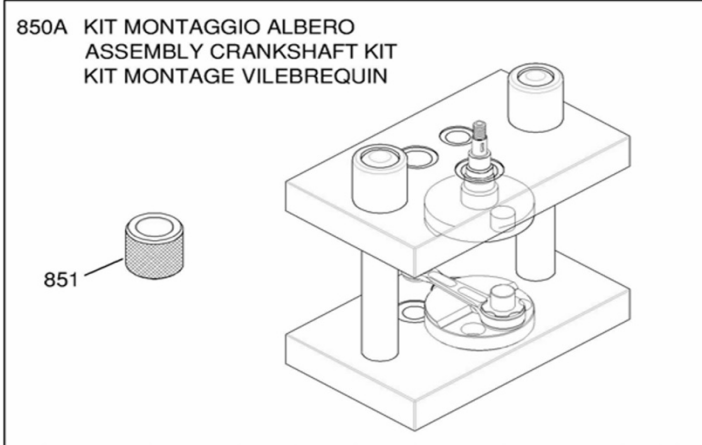

KT-013

POS	PART #	DESCRIPTION	USA RETAIL
850A	10110A	CRANKSHAFT ASSY TOOL	\$ 2,071.44
851	10150A	CRANK-PIN BUSH 20mm	\$ 57.11
853	10100	CRANKSH. DISASSY SUPPORT	\$ 230.04
854	10104A	CRANKSHAFT PLATE 125cc	\$ 87.52
855	10106	CRANKSHAFT INSERT 125cc-SUP	\$ 91.27
856	10107	CRANK-PIN PUSHER	\$ 22.77
857A	10820A	TIMING CHECK DISC TaG/REEDSTER	\$ 130.02
858A	ATT-014-C	COMPLETE TIMING GROUP ADAPTER	\$ 33.81