



## SUPER SHIFTER - 175cc - TaG



### FEATURES - CARACTERISTIQUES

Cylinder volume <i>Volume du cylindre</i>	174.56 cm <sup>3</sup> <b>(Max 175.5 cm<sup>3</sup>)</b>
Bore <i>Alésage</i>	63.92 mm
Max. theoretical bore <i>Alésage théorique max.</i>	64.04 mm
Stroke <i>Course</i>	54.40 mm
Distance between conrod centers <i>Longueur (entre axe) de la bielle</i>	115 mm
Cooling system <i>Système de refroidissement</i>	Water <i>Eau</i>
Inlet system <i>Système d'admission</i>	Reed valve <i>À clapets</i>
Cylinder / crankcase transfers n° <i>N° de canaux cylindre / carter</i>	5 / 3

Carburetor  
*Carburateur*

Dell'Orto  
VHSB 36 -  
RD

Inlet / exhaust ports number  
*N° lumières adm. / échapp.*

5 / 3

Number of piston rings  
*Nombre de segments*

1

Combustion chamber shape  
*Forme chambre de combustion*

Spherical  
*Sphérique*

Big end conr. bearing diam.  
*Diamètre palier tête de bielle*

20x26x15

Selettra ignition  
*Allumage Selettra*

Digital "K"

Crankshaft bearing diam.  
*Diamètre palier du vilebrequin*

25x52x15 (2Pc.)  
15x35x11 (1Pc.)

Generator for battery charging  
*Générateur de recharge batterie*

Yes  
*Oui*

Small end conr. bearing diam.  
*Diamètre palier pied de bielle*

15x19x20

Electric starter  
*Démarrateur électrique*

Yes  
*Oui*

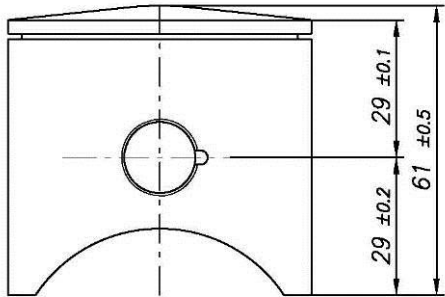
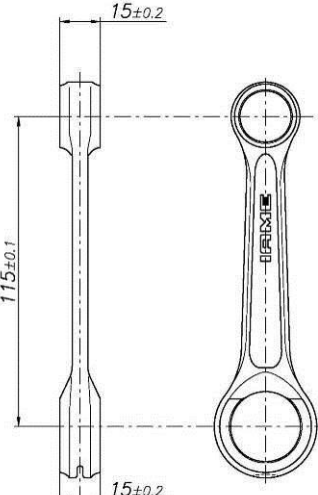
DESCRIPTION OF THE MATERIAL DESCRIPTION DES MATERIAUX		PISTON
Conrod material <i>Matériel de la bielle</i>	Steel <i>Acier</i>	 <p>Piston min. weight (ring incl.) 155 g <i>Poids min. piston (avec segment) 155 g</i></p>
Crankshaft material <i>Matériel du vilebrequin</i>	Steel <i>Acier</i>	
Gearbox shafts material <i>Matériel de l'arbres de boîte de vitesses</i>	Steel <i>Acier</i>	
Gears material <i>Matériel des engrenages</i>	Steel <i>Acier</i>	
Starter ring material <i>Matériel de la couronne démarr.</i>	Steel / <i>Acier</i> or / ou Aluminium	
Head material <i>Matériel de la culasse</i>	Aluminium	DISTANCE BETWEEN CONROD CENTERS <i>ENTRE AXE DE LA BIELLE</i>
Cylinder material <i>Matériel du cylindre</i>	Aluminium	 <p>Min. Weight 112 g <i>Poids min. 112 g</i></p>
Liner material <i>Matériel de la chemise</i>	Iron <i>Fonte</i>	
Crankcase material <i>Matériel du carter</i>	Aluminium	
Piston material <i>Matériel du piston</i>	Aluminium	
Piston rings material <i>Matériel des segments</i>	Iron <i>Fonte</i>	
Exhaust muffler material <i>Matériel du pot d'échappement</i>	Sheet-steel <i>Tôle acier</i>	

### CRANKSHAFT – VILEBREQUIN

Complete crankshaft min. weight 2070 g  
*Poids min. du vilebrequin complet 2070 g*

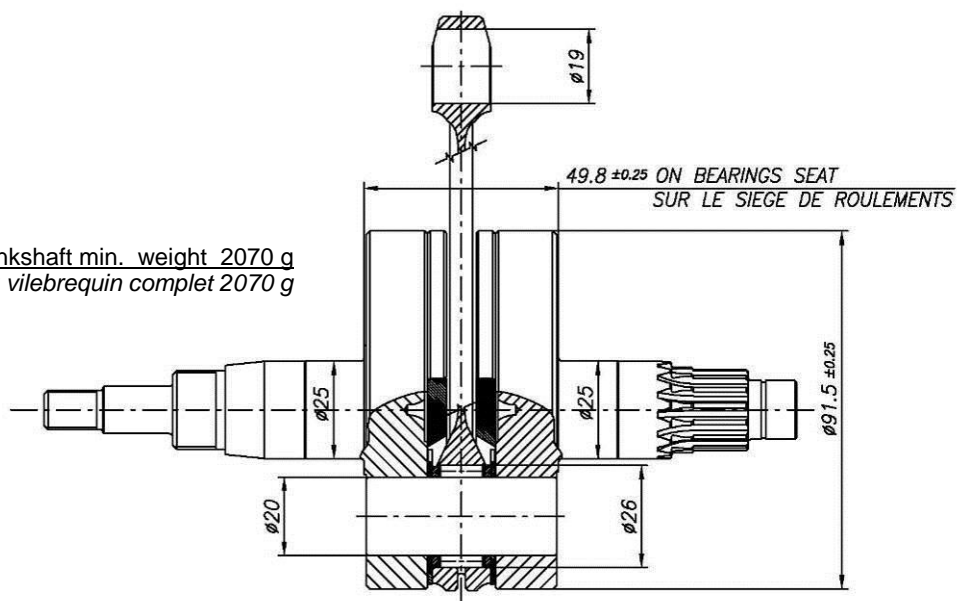

CYLINDER DEVELOPMENT - DEVELOPPEMENT DU CYLINDRE

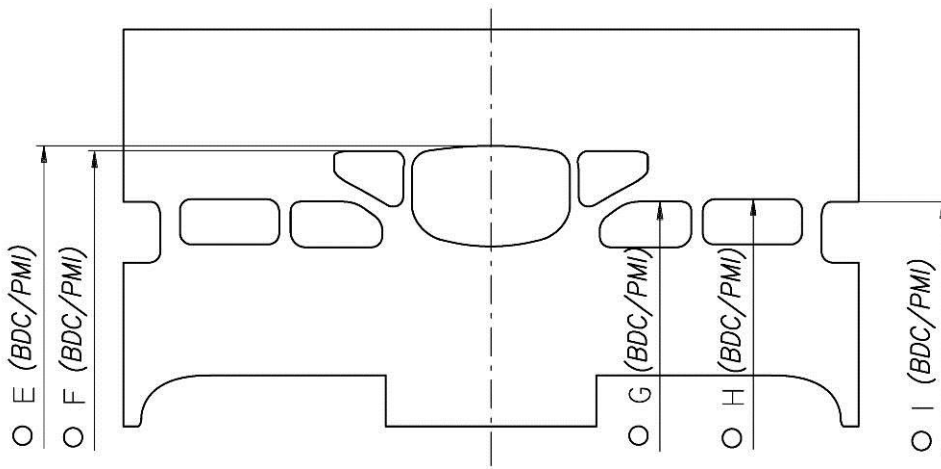

E	$195^\circ \pm 2^\circ$
F	$189^\circ \pm 2^\circ$
G	$122.5^\circ \pm 2^\circ$
H	$125.5^\circ \pm 2^\circ$
I	$121^\circ \pm 3^\circ$

○ ANGULAR READING BY INSERTING A 0.2x5mm GAUGE  
 LECTURE ANGULAIRE PAR INSERTION D'UNE CALE DE 0.2x5mm

CYLINDER BASE VIEW  
 VUE DE LA BASE DU CYLINDRE

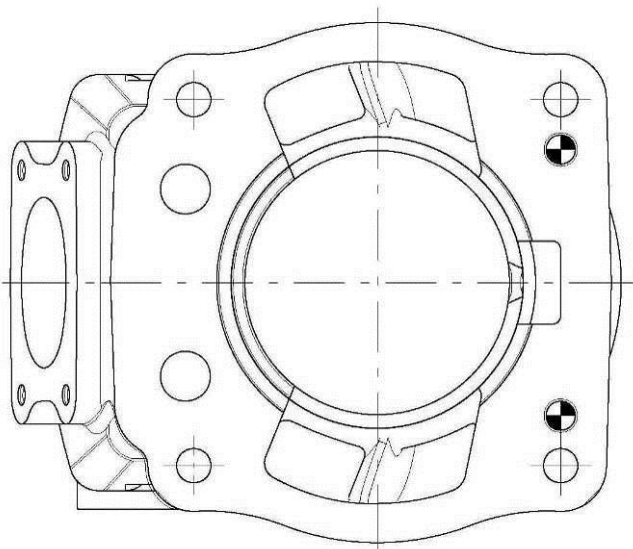

CYLINDER CROSS SECTION VIEW  
 VUE EN SECTION DU CYLINDRE

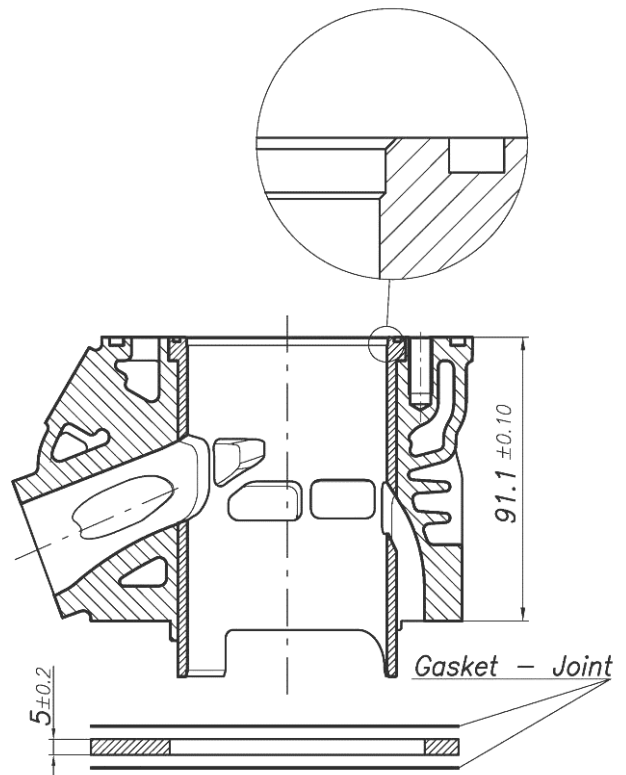

COMBUSTION CHAMBER VIEW  
VUE DE LA CHAMBRE DE COMPRESSION

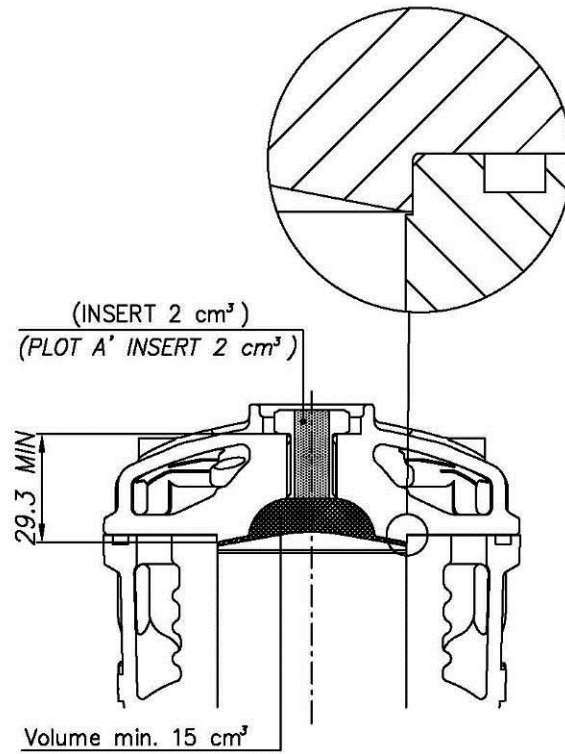

COMBUSTION CHAMBER VOLUME TOT. = 17 cm<sup>3</sup> min.  
VOLUME CHAMBRE COMBUSTION TOT. = 17 cm<sup>3</sup> min.

SQUISH MIN. = 1 mm  
(measured with Ø1.5mm TIN - mesurée avec de l'étain Ø1.5mm)

CRANKCASE INSIDE VIEW  
VUE A' L' INTERIEUR DU CARTER

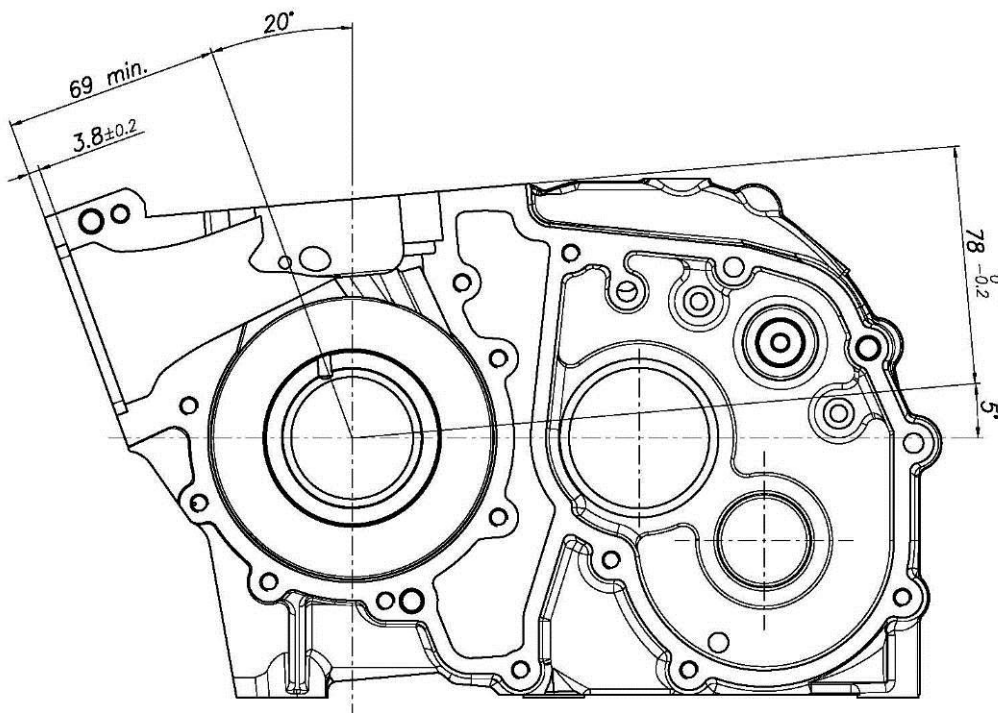

REED VALVE  
BOÎTE À CLAPETS

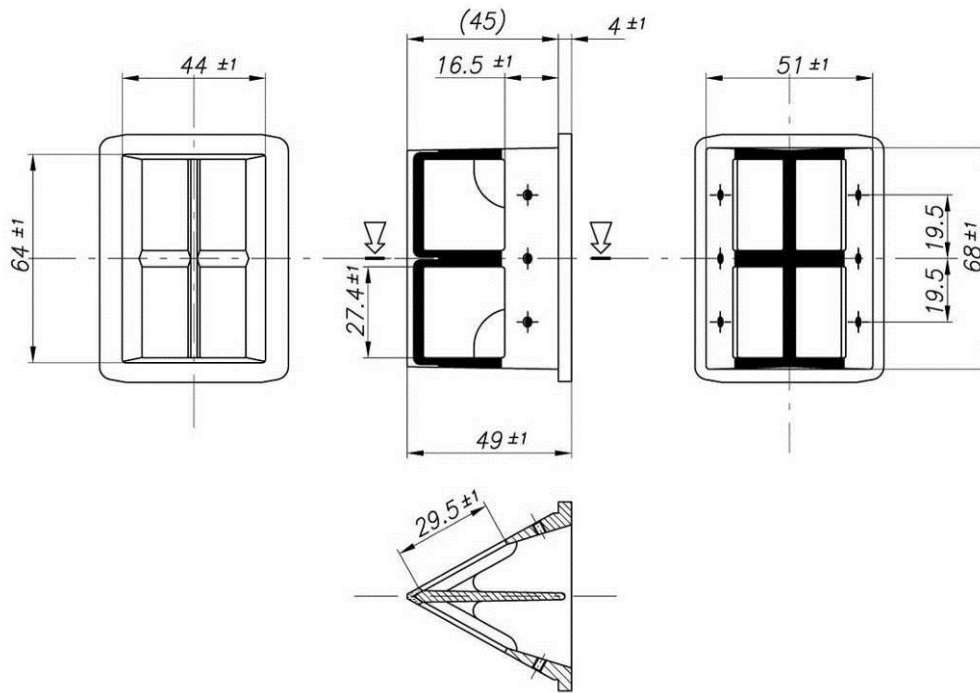

ASSEMBLY OF REED VALVE  
DESSIN D'ENSEMBLE DE LA BOÎTE À CLAPETS

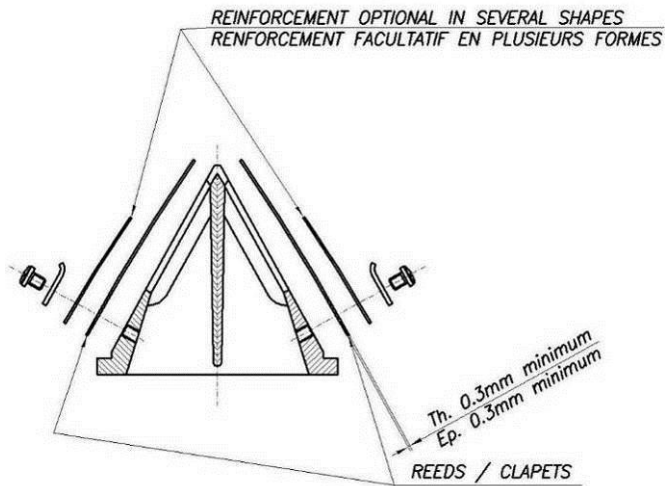

REEDS / CLAPETS

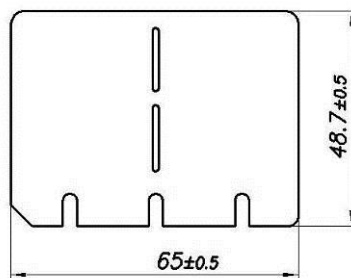

N.B.: ONLY REED "IAME" GENUINE CARBON FIBER ARE PERMITTED.

N.B. : SEULS LES CLAPETS D'ORIGINE "IAME" EN FIBRE DE CARBONE SONT AUTORISES.

CARBURETOR FITTING RUBBER  
 RACCORD DU CARBURATEUR EN CAOUTCHOUC

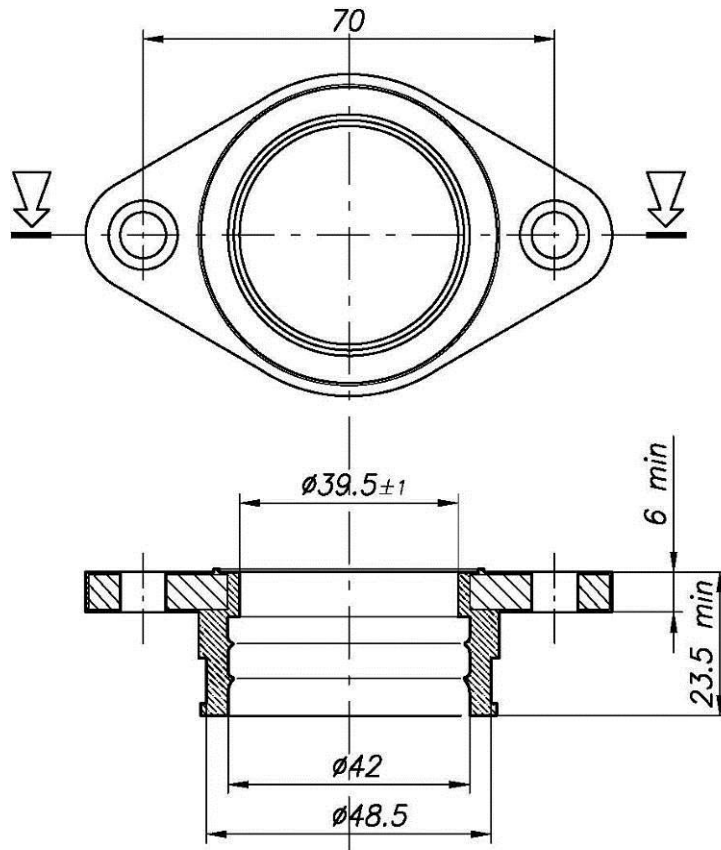

REED VALVE COVER  
 COUVERCLE DE LA BOÎTE A CLAPETS

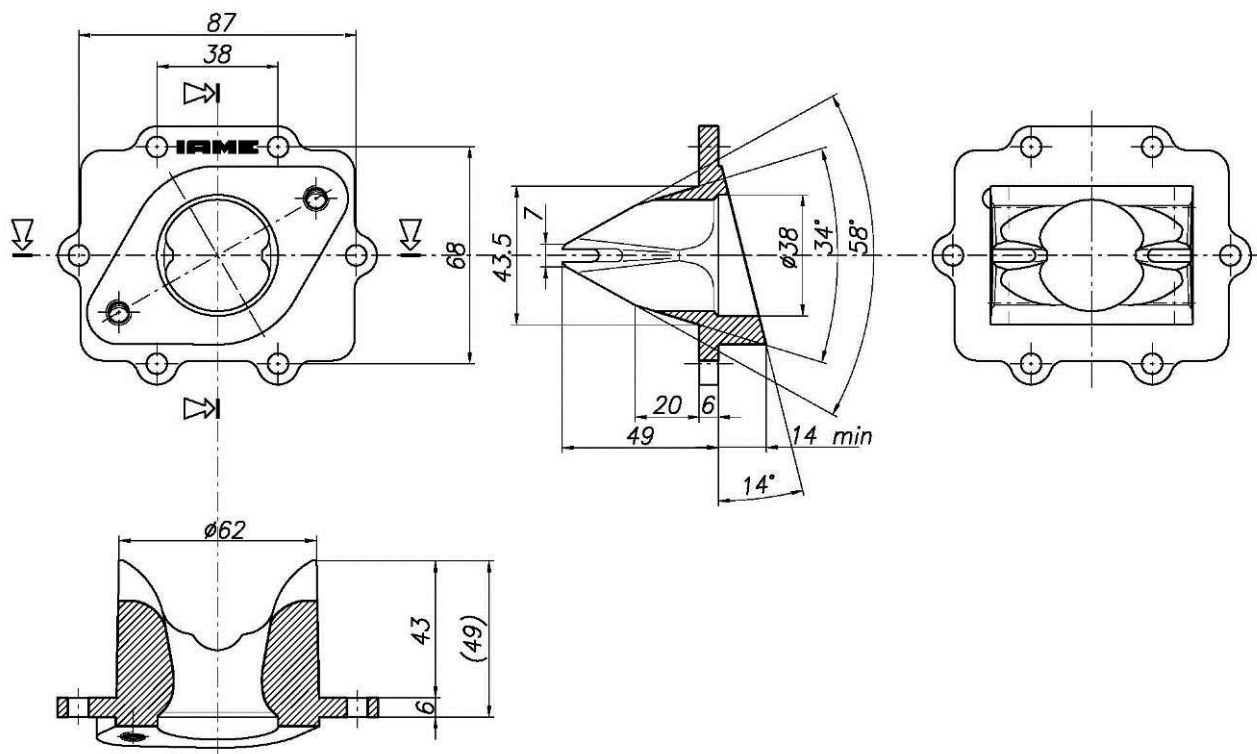

## GEARBOX - BOÎTE DE VITESSES

Primary coupling - *Couple primaire* **19 / 75**

Gearbox ratios		<i>Rapports de boîte de vitesses</i>	
Gear - <i>Vitesse</i>	Primary shaft <i>Arbre primaire</i>	Secondary shaft <i>Arbre secondaire</i>	Reading of values obtained after three engine revs <i>Relevé des valeurs obtenues après trois tours moteur</i>
1 <sup>st</sup> / 1 <sup>ere</sup>	<b>13</b>	<b>33</b>	<b>107.78°</b>
2 <sup>nd</sup> / 2 <sup>e</sup>	<b>16</b>	<b>29</b>	<b>150.95°</b>
3 <sup>rd</sup> / 3 <sup>e</sup>	<b>18</b>	<b>27</b>	<b>182.40°</b>
4 <sup>th</sup> / 4 <sup>e</sup>	<b>22</b>	<b>27</b>	<b>222.93°</b>
5 <sup>th</sup> / 5 <sup>e</sup>	<b>22</b>	<b>23</b>	<b>261.70°</b>
6 <sup>th</sup> / 6 <sup>e</sup>	<b>27</b>	<b>25</b>	<b>295.49°</b>

EXPLODED DRAWING OF THE GEARS, MAINSHAFT AND SECONDARY SHAFT  
*DESSIN EXPLODÉ DES ENGRANAGES, ARBRE PRIMAIRE ET ARBRE SECONDAIRE*

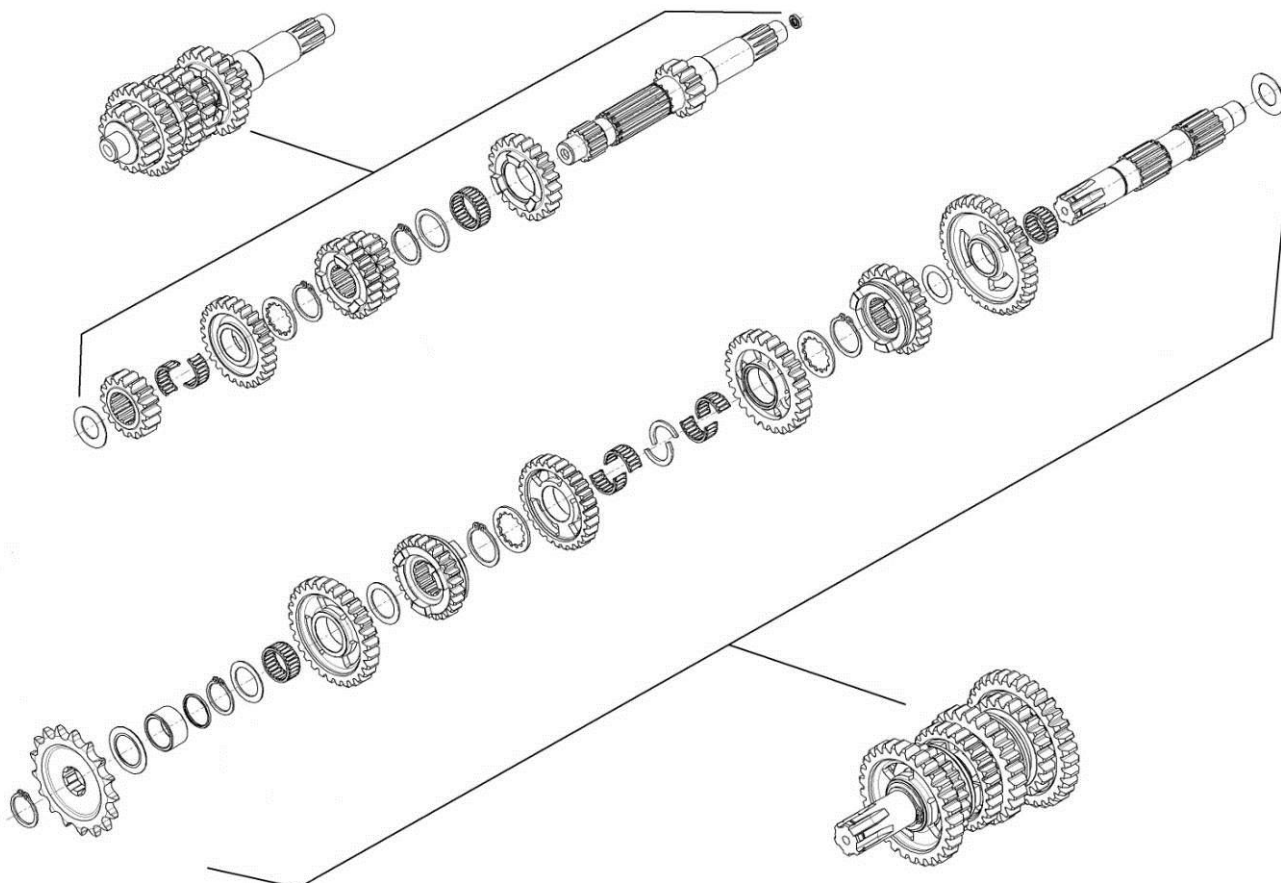

EXHAUST VIEW, PHOTO AND DIMENSIONS  
 VUE, PHOTO ET DIMENSIONS DE L'ÉCHAPPEMENT

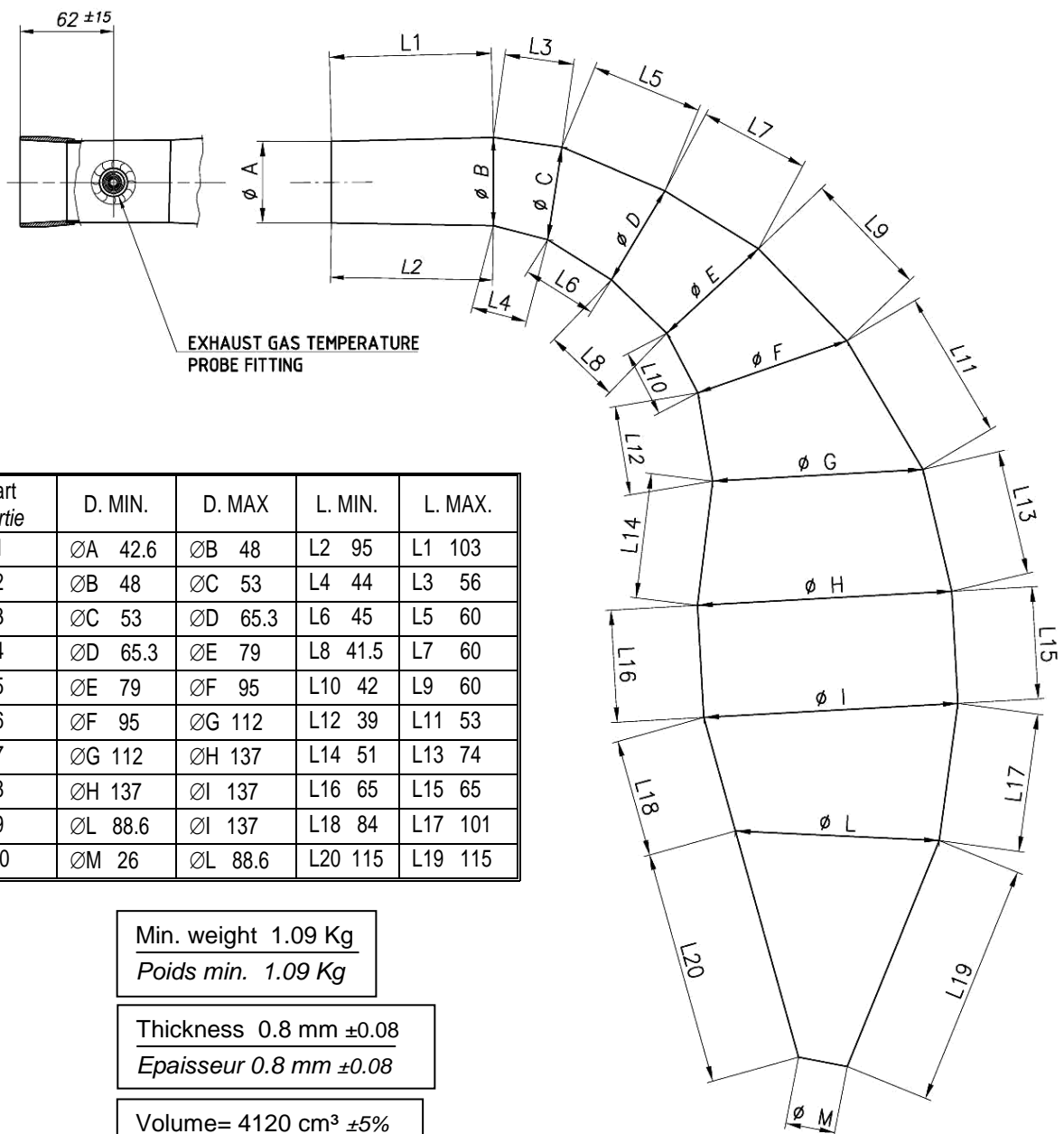





EXPLODED DRAWING AND VENTURI CARB. "DELLORTO VHSB 36-RD" DIMENSIONS  
 DESSIN EXPLOSÉ ET DIMENSIONS DU VENTURI DU CAR. "DELLORTO VHSB 36-RD"

1. Throttle Valve - SOUPAPE GAZ
2. Conical Needle - AIGUILLE CONIQUE
3. Sprayer - PULVERISATEUR
4. Minimum Emulsifier - EMULSIONNEUR
5. L. Jet - GICLEUR MIN.
6. H Jet - GICLEUR MAX.
7. Starter Jet - GICLEUR DEMARREUR
8. Needle Valve - POINTEAU
- 9A. Single Floating - FLOTTEUR INDEPENDANT
- 9B. Coupled Floating - PAIRE DE FLOTTEUR
10. Cap - BOUCHON
11. Screw Adjuster - VIS REGLAGE
12. Cover Mixing Chamber - COUVERCLE CHAMBRE DE MELANGE
13. Cover Gasket - JOINT COUVERCLE
14. Throttle Return Spring - RESSORT RETOUR SOUPAPE
15. Bottom Spring Guide - CULOT
16. Nipple Throttle Valve + Spring - RACCORD ROBINET GAZ + RESSORT
17. Washer - RONDELLE
18. Clip Needle - FERMOIR POINTEAU
19. Start Fixing Screw - VIS FIXATION DISPOSITIF DEMARRAGE
20. Starter Device - DISPOSITIF DEMARRAGE
21. Starter Device Seal - JOINT DISP. DEMARRAGE
22. Idle Mixture Screw - VIS MELANGE MINIMUM
23. Kit Throttle Adjusting Screw - KIT VIS REGLAGE SOUPAPE
24. Kit Fuel Filter - KIT FILTRE CARBURANT
25. Needle Valve Seal - JOINT POINTEAU
26. Bottom - CULOT
27. Gasket - JOINT
28. Float Chamber - CUVETTE
29. Fixing Screw Float Chamber - VIS FIXATION CUVETTE
30. Spring Washer - RONDELLE RESSORT
31. Pin Float - AXE DE FLOTTEUR
32. Tank Cap Seal - JOINT BOUCHON CUVETTE
33. Float Chamber Plug - BOUCHON CUVETTE
35. Rocker Float - BALANCIER FLOTTEUR

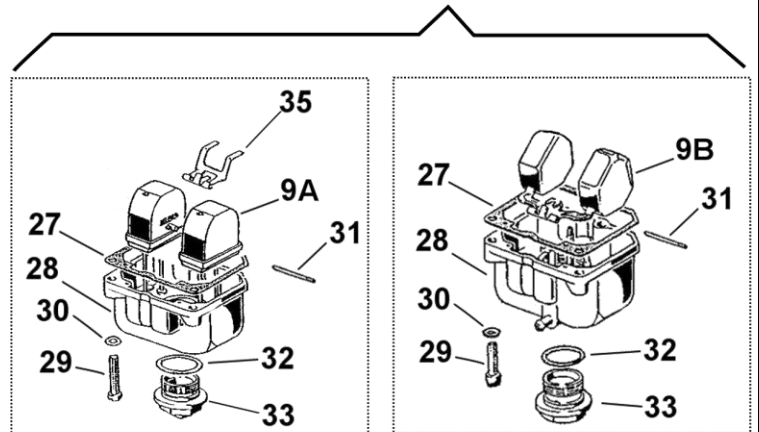
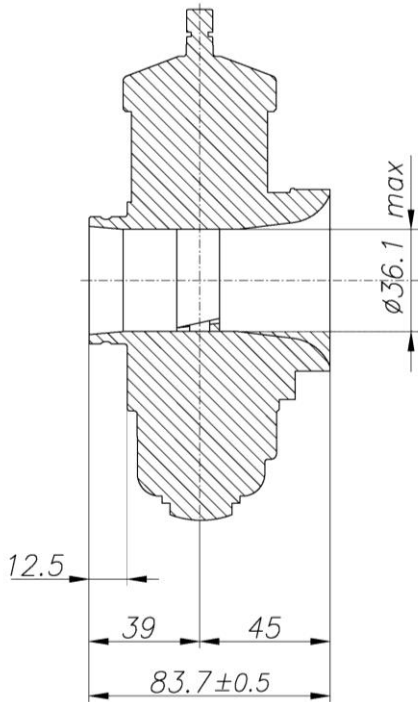
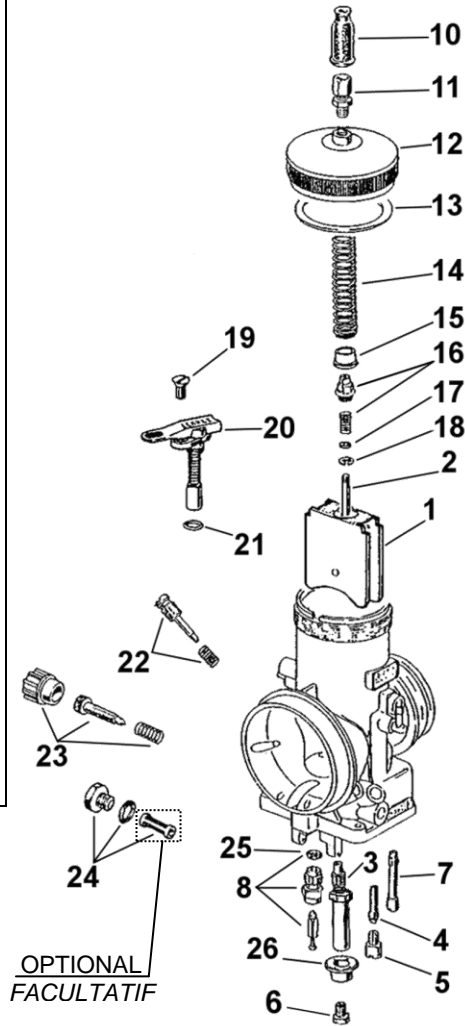

SELETTRA - ELECTRONIC BOX MARKING  
SELETTRA - MARQUAGE DU BOITIER ELECTRONIQUE

PRODUCTION DATE  
DATE DE FABRICATION

SUPPLIER PART NUMBER  
N° REF. FOURNISSEUR

IAME MARKING  
MARQUAGE IAME

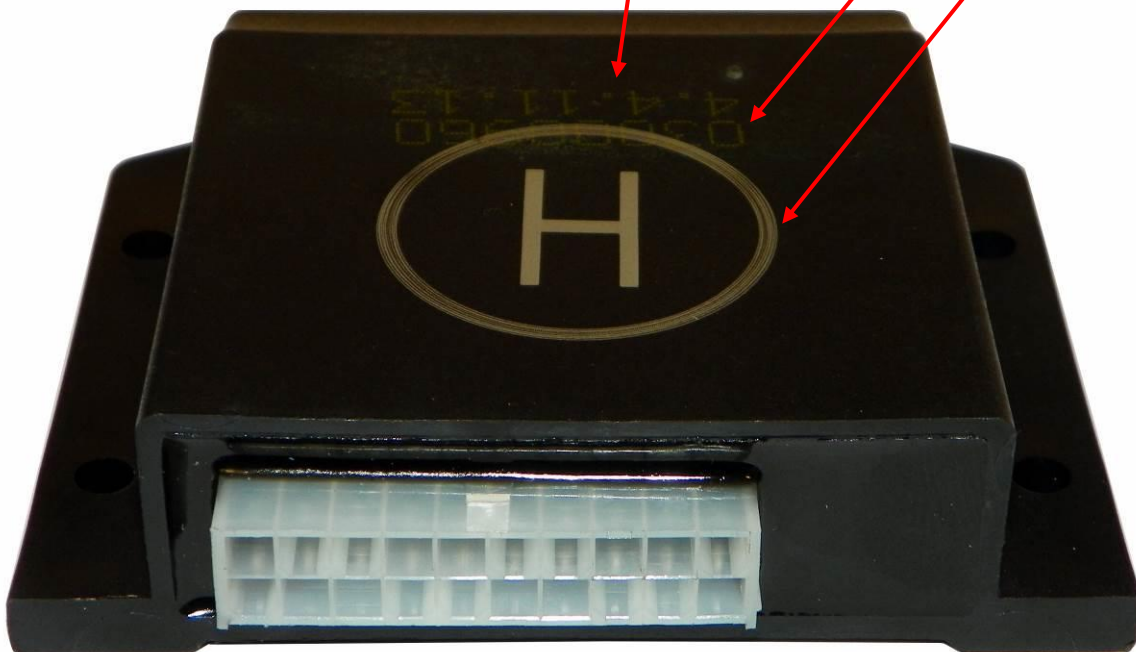

WIRING DIAGRAM ( SELETTRA DIGITAL "K" IGNITION )  
 SCHEMA CIRCUIT ELECTRIQUE ( ALLUMAGE SELETTRA DIGITAL "K" )

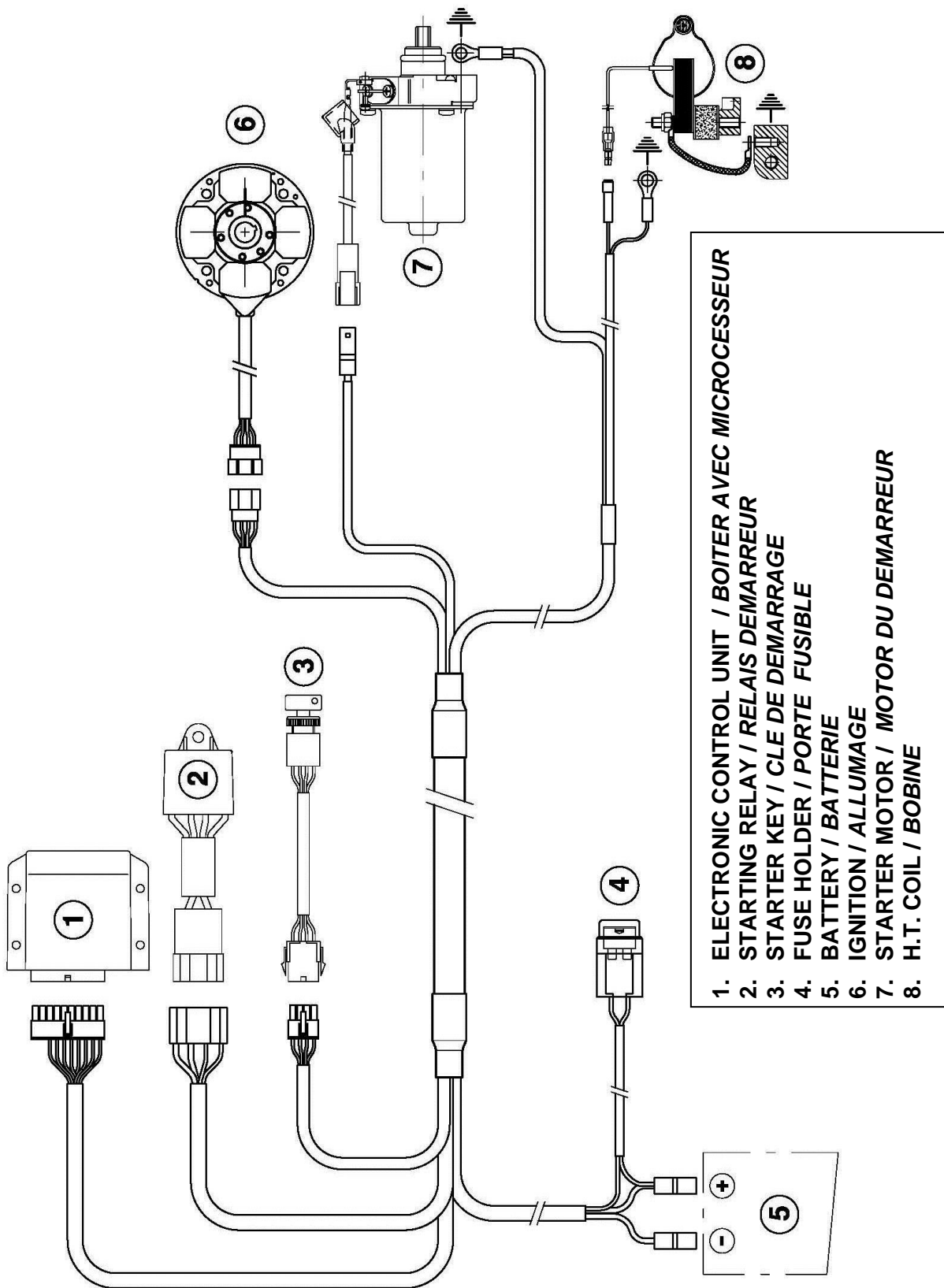

1. ELECTRONIC CONTROL UNIT / BOITIER AVEC MICROCESSEUR
2. STARTING RELAY / RELAIS DEMARRREUR
3. STARTER KEY / CLE DE DEMARRAGE
4. FUSE HOLDER / PORTE FUSIBLE
5. BATTERY / BATTERIE
6. IGNITION / ALLUMAGE
7. STARTER MOTOR / MOTOR DU DEMARREUR
8. H.T. COIL / BOBINE